

QT Series Model QT-15

Parts Manual
Record of Change 102

This manual contains important safety information and must be carefully read in its entirety and understood prior to installation by all personnel who install, operate and/or maintain this product.

On-line product registration, parts ordering and warranty information is available at www.quincycompressor.com

Manual No. 50250-102

February 2005 Edition

TABLE OF CONTENTS

Serial Number Identification.....	2
Ordering Replacement Parts.....	2
Quin-Cip Lubricant.....	2
Crankcase Lubricant Capacity.....	2
Crankcase Group.....	3
Crankshaft Group.....	4
Connecting Rod & Piston Groups.....	5-8
Cylinder & Head Groups.....	9-16
Manifold Group.....	17
Control Piping Schematics.....	18
Pilot Valves.....	19
Pilot Valve Repair Kit.....	19
Differential Setting Charts.....	19
Suction Valve Unloader Assemblies.....	20
Decals.....	20
Gasket Set.....	21
Recommended Spare Parts.....	21
Overhaul Kits.....	21
Head Kits.....	21
Typical Unit Repair Parts List.....	22-23

INTRODUCTION

This manual provides information for the Model QT-15 reciprocating compressor, per Record of Change 102.

The Model QT-15 is an aircooled, two stage, four cylinder, V-type, splash lubricated compressor, with up to 175 PSI continuous pressure capability. It has a 4.5" low pressure bore and a 2.5" high pressure bore, with a 3.5" stroke. This compressor can be run at 600-1150 RPM.

Available options include:

-head unloaders

CHANGES

since previous printing dated May 2002:

Redesigned crankcase, bearing carrier and connecting rods, and implemented side-sealer (tapered edge) type piston rings.

SERIAL NUMBER IDENTIFICATION

The unit serial number identification tag is located on the air tank top plate. The basic compressor serial number decal is located on the side of the crankcase opposite the oil fill side. *Fill in the numbers from your compressor unit and basic compressor in the corresponding spaces provided here, and reference this page when ordering replacement parts.*

Unit Serial Number

Basic Serial Number

All replacement parts are to be ordered through an authorized Quincy distributor. Insist on genuine Quincy parts only! Failure to do so may void warranty.

ORDERING REPLACEMENT PARTS

Prompt service can be rendered on repair parts orders if the following information is given:

- Item 1)** the model number, record of change number, & serial number.
- Item 2)** the exact part number needed. (Do not order by item numbers.)
- Item 3)** the exact quantity needed.
- Item 4)** the preferred type of transportation.

CRANKCASE LUBRICANT CAPACITY

Model	Capacity
QT-15	3 qts. & 24 oz. (3.55 lit.)

QUIN-CIP LUBRICANT

Refer to the chart below to order Quin-Cip compressor lubricant from your local authorized Quincy distributor.

Quin-Cip-D Lubricant (synthetic)	
SAE 30 (ISO 100)	
Quart	115468Q
Case (12 Qts.)	115438C
Quin-Cip Lubricant	
SAE 10W (ISO 32)	
Quart	112541Q032
Case (12 Qts.)	112541C032
SAE 20 (ISO 68)	
Quart	112542Q068
Case (12 Qts.)	112542C068
SAE 30 (ISO 100)	
Quart	112543Q100
Case (12 Qts.)	112543C100

CAUTION !

Refer to the QT and QTS Series instruction manual for vital lubrication information.

CAUTION !

Follow all safety precautions outlined in the QT and QTS Series instruction manual.

WARNING !

Do not operate this compressor without a totally enclosed belt guard or any other required safety equipment.

DANGER !

Air used for breathing or food processing must meet OSHA 1910.134 or FDA 21 CFR 178.3570 regulations. Failure to do so may cause severe injury or death.

CRANKCASE GROUP 111929-002

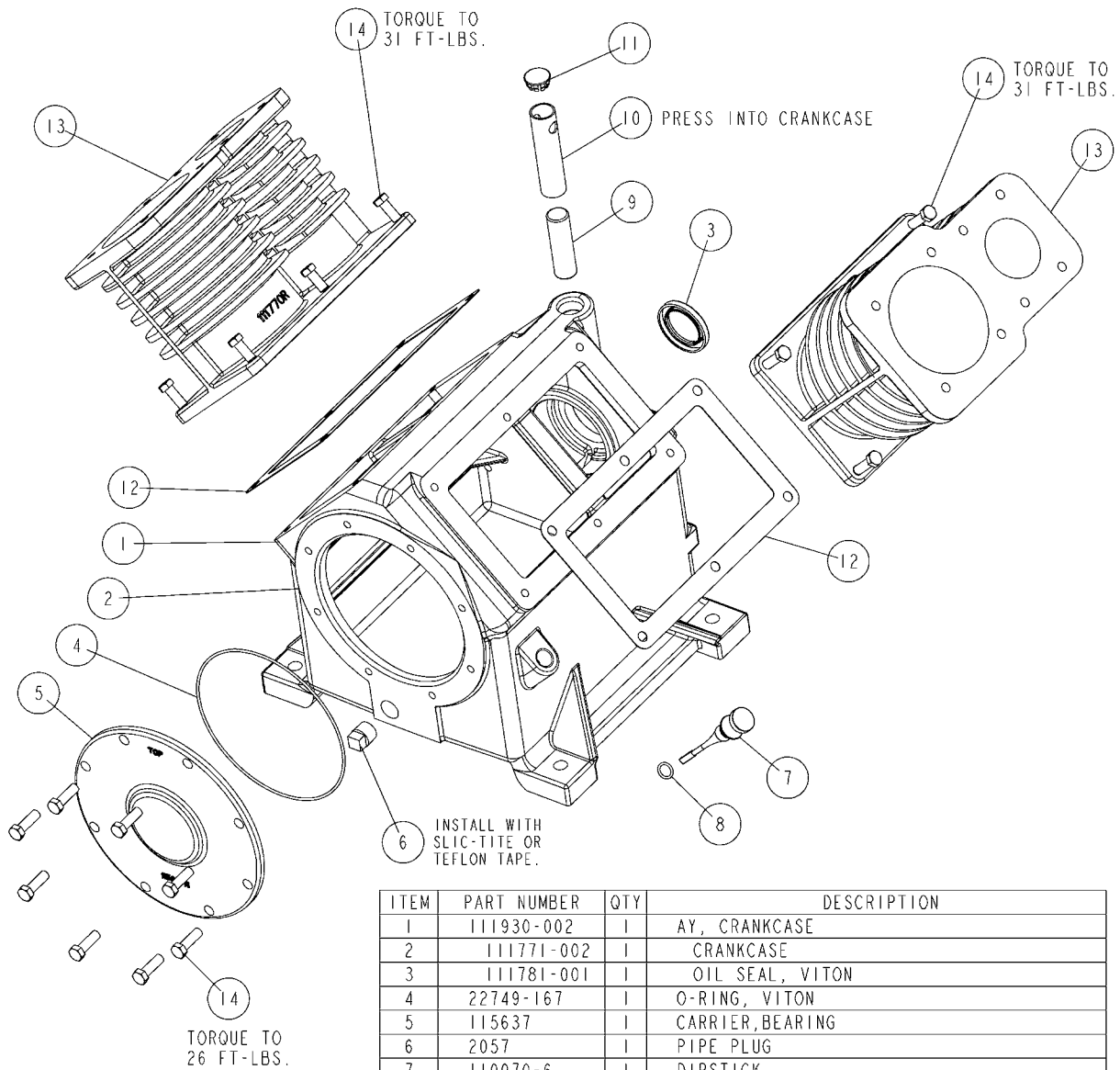

ITEM	PART NUMBER	QTY	DESCRIPTION
1	111930-002	1	AY, CRANKCASE
2	111771-002	1	CRANKCASE
3	111781-001	1	OIL SEAL, VITON
4	22749-167	1	O-RING, VITON
5	115637	1	CARRIER, BEARING
6	2057	1	PIPE PLUG
7	110070-6	1	DIPSTICK
8	123157-112	1	O-RING
9	111333	1	FILTER
10	113947	1	BREATHER TUBE
11	40825	1	HOLE PLUG
12	111782	2	CYLINDER GASKET
13	111770	2	CYLINDER
14	115037-L14	20	SCREW, CAP HEX, SEALANT, GRADE 5

CRANKSHAFT GROUP 111933

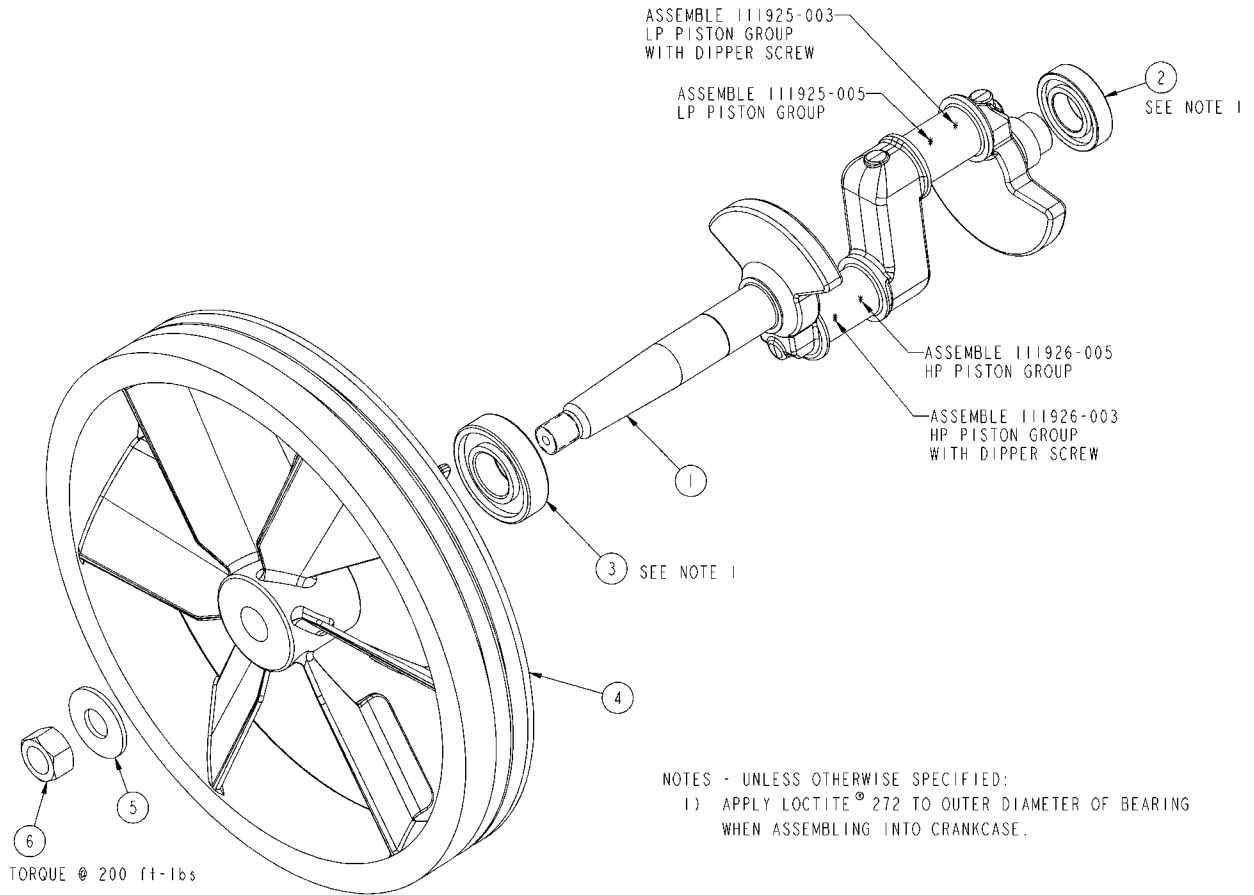

ITEM	PART NUMBER	QTY	DESCRIPTION
1	111775-001	1	CRANKSHAFT
2	111780	1	BALL BEARING
3	111779	1	BALL BEARING
4	111776	1	SHEAVE, 19.50 O.D., 2 GROOVE, B SECT. CCW
5	110428W100	1	FLAT WASHER, 1
6	112352	1	NUT, HEX 1-14UNF, L.H. THREAD
REPLACEMENT PARTS			
	111934		CRANKSHAFT ASSEMBLY INCLUDES: CRANKSHAFT & BEARINGS

CONNECTING ROD & PISTON GROUP 111925-003

(low pressure, with dipper screw)

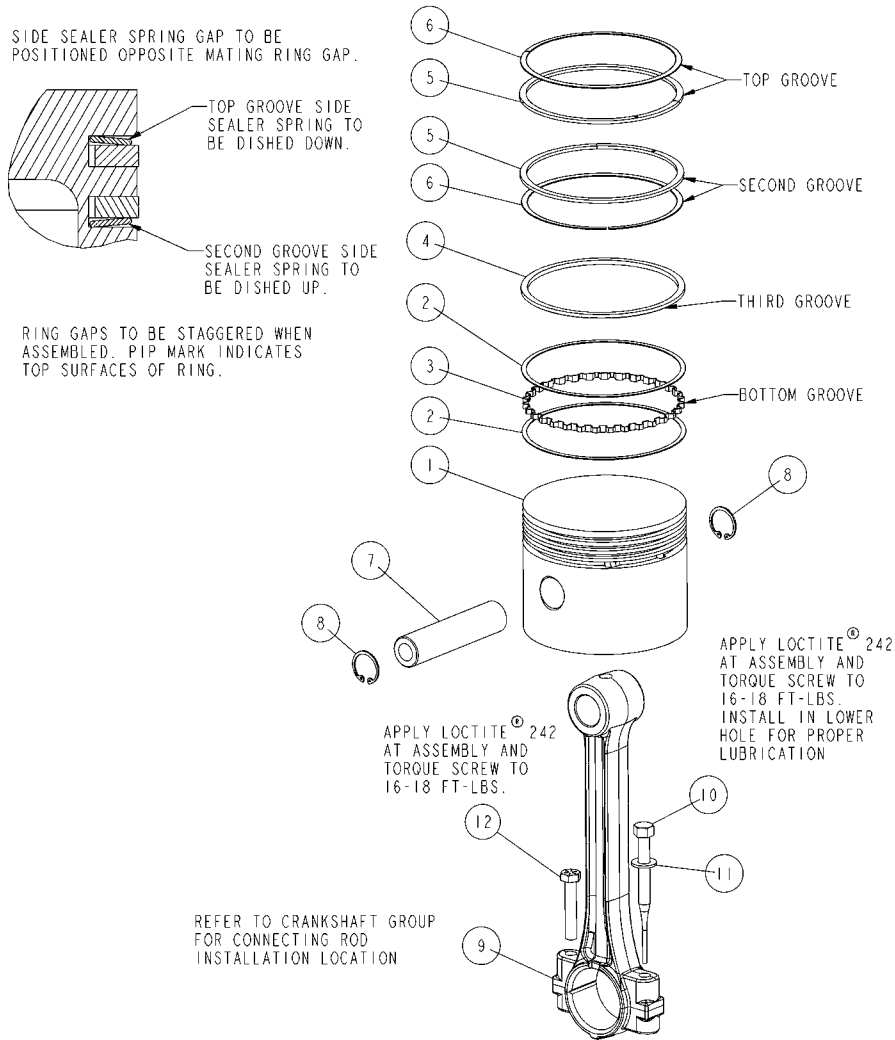

ITEM	PART NUMBER	QTY	DESCRIPTION
1	8643	1	PISTON, LP
2	112781	2	OIL RING RAIL
3	112780	1	OIL RING EXPANDER
4	7351	1	PISTON RING
5	7010	2	PISTON RING
6	7012	2	SPRING, SIDE SEALER
7	8646	1	PISTON PIN
8	8648	2	RETAINING RING
9	115590-001	1	CONROD ASSY, LP
10	115564	1	DIPPER SCREW
11	110428N031	1	FLAT WASHER, 5/16
12	115388-K16	1	SCREW, ZINC, GRADE 8
MAINTENANCE PARTS			
	8166	1	PISTON RING SET
	115814X	1	PISTON ASSEMBLY, LP INCLUDES PISTON, RING SET, PISTON PIN, AND RETAINING RINGS.
	110190-052	1	REPLACEMENT PISTON PIN ASSEMBLY, LP INCLUDES PISTON PIN AND RETAINING RINGS

CONNECTING ROD & PISTON GROUP 111925-005

(low pressure)

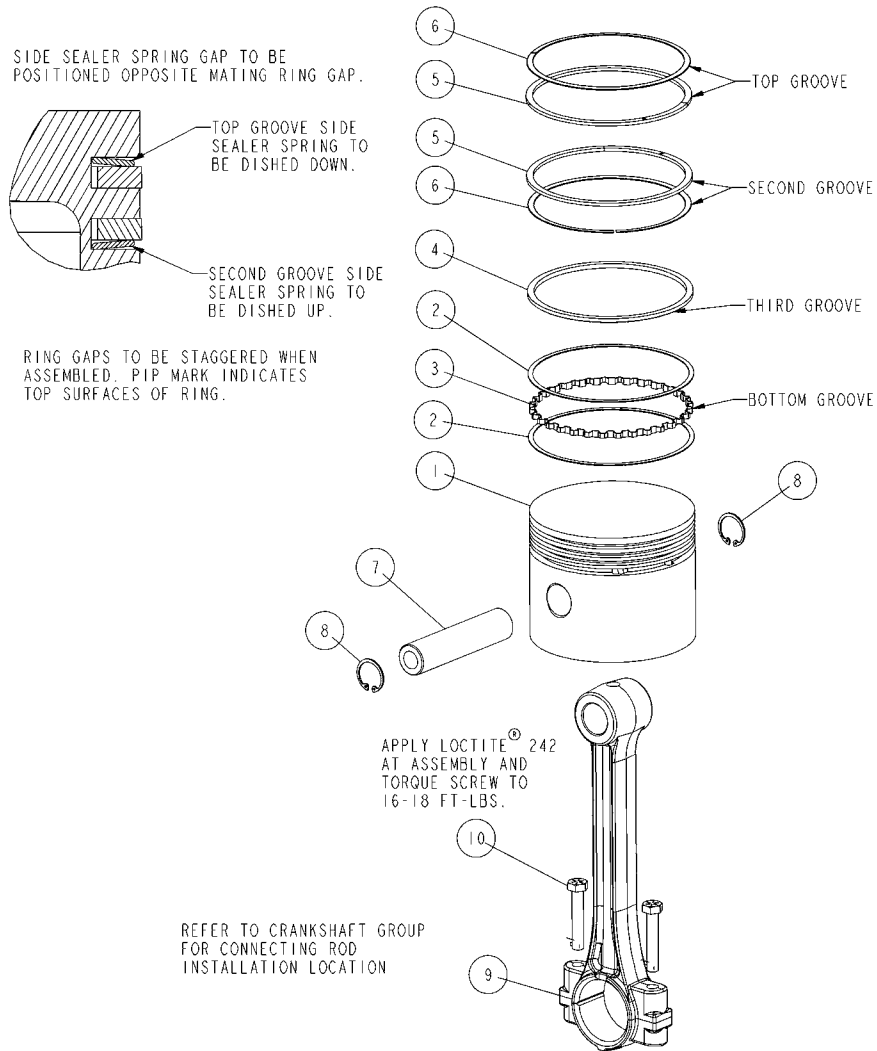

ITEM	PART NUMBER	QTY	DESCRIPTION
1	8643	1	PISTON, LP
2	112781	2	OIL RING RAIL
3	112780	1	OIL RING EXPANDER
4	7351	1	PISTON RING
5	7010	2	PISTON RING
6	7012	2	SPRING, SIDE SEALER
7	8646	1	PISTON PIN
8	8648	2	RETAINING RING
9	115590-001	1	CONROD ASSY, LP
10	115388-K16	2	SCREW, ZINC, GRADE 8
MAINTENANCE PARTS			
	8166	1	PISTON RING SET
	115814X	1	PISTON ASSEMBLY, LP INCLUDES PISTON, RING SET, PISTON PIN, AND RETAINING RINGS.
	110190-052	1	REPLACEMENT PISTON PIN ASSEMBLY, LP INCLUDES PISTON PIN AND RETAINING RINGS

CONNECTING ROD & PISTON GROUP 111926-003

(high pressure, with dipper screw)

SIDE SEALER SPRING GAP TO BE POSITIONED OPPOSITE MATING RING GAP.

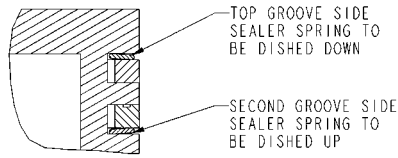

RING GAPS TO BE STAGGERED WHEN ASSEMBLED. PIP MARK INDICATES TOP SURFACES OF RING.

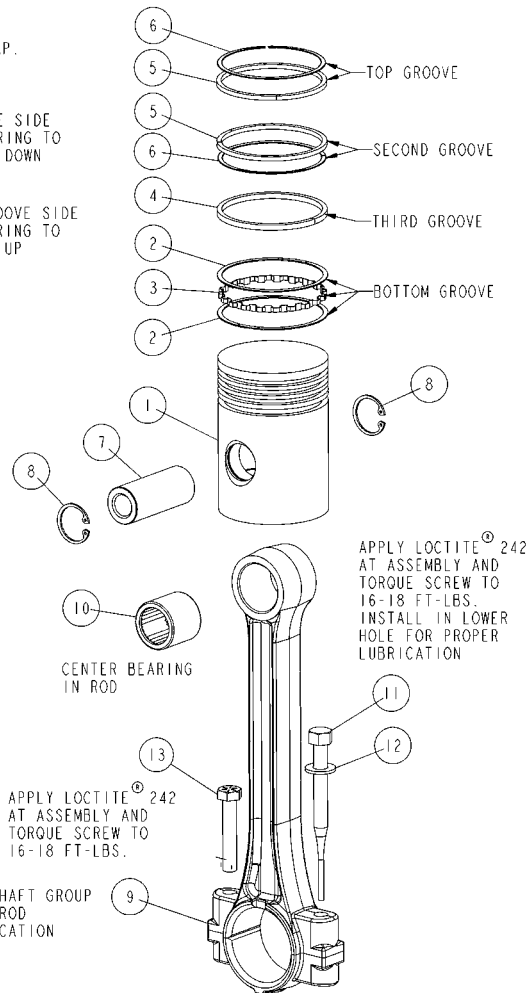

ITEM	PART NUMBER	QTY	DESCRIPTION
1	1530-001	1	PISTON
2	111281	2	OIL RING RAIL
3	111280	1	OIL RING EXPANDER
4	1652	1	PISTON RING
5	6536	2	RING, PISTON
6	6538	2	SPRING, SIDE SEALER
7	110190-021	1	PISTON PIN (N.S.S., ORDER REPLACEMENT PIN ASSEMBLY)
8	8648	2	RETAINING RING
9	111927-003	1	AY, CONROD, H.P.
10	112301	1	NEEDLE BEARING
11	115564	1	DIPPER SCREW
12	110428N031	1	FLAT WASHER, 5/16
13	115388-K16	1	SCREW, ZINC, GRADE 8
MAINTENANCE PARTS			
	8161	1	PISTON RING SET
	115815X	1	PISTON ASSEMBLY, HP INCLUDES PISTON, RING SET, PISTON PIN, AND RETAINING RINGS.
	110190-053	1	REPLACEMENT PISTON PIN ASSEMBLY, HP INCLUDES PISTON PIN AND RETAINING RINGS

CONNECTING ROD & PISTON GROUP 111926-005 (high pressure)

SIDE SEALER SPRING GAP TO BE POSITIONED OPPOSITE MATING RING GAP.

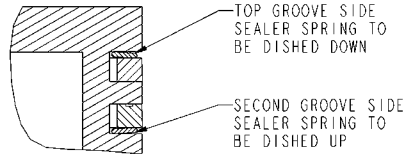

RING GAPS TO BE STAGGERED WHEN ASSEMBLED. PIP MARK INDICATES TOP SURFACES OF RING.

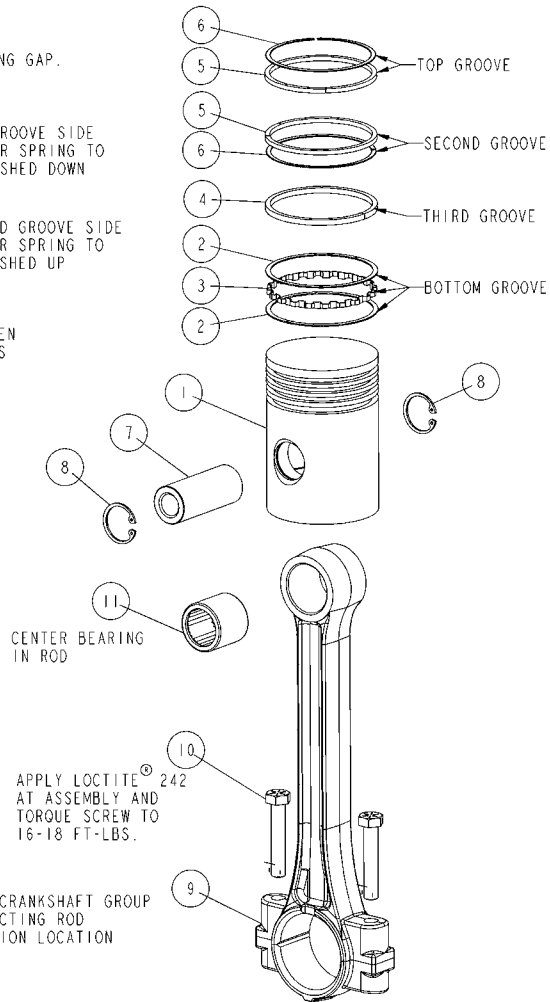

ITEM	PART NUMBER	QTY	DESCRIPTION
1	1530-001	1	PISTON
2	111281	2	OIL RING RAIL
3	111280	1	OIL RING EXPANDER
4	1652	1	PISTON RING
5	6536	2	RING, PISTON
6	6538	2	SPRING, SIDE SEALER
7	110190-021	1	PISTON PIN (N.S.S., ORDER REPLACEMENT PIN ASSEMBLY)
8	8648	2	RETAINING RING
9	111927-003	1	AY, CONROD, H.P.
10	115388-K16	2	SCREW, ZINC, GRADE 8
11	112301	1	NEEDLE BEARING
MAINTENANCE PARTS			
	8161	1	PISTON RING SET
	115815X	1	PISTON ASSEMBLY, HP INCLUDES PISTON, RING SET, PISTON PIN, AND RETAINING RINGS.
	110190-053	1	REPLACEMENT PISTON PIN ASSEMBLY, HP INCLUDES PISTON PIN AND RETAINING RINGS

HEAD GROUP 111935-1

(*right bank / less head unloaders)

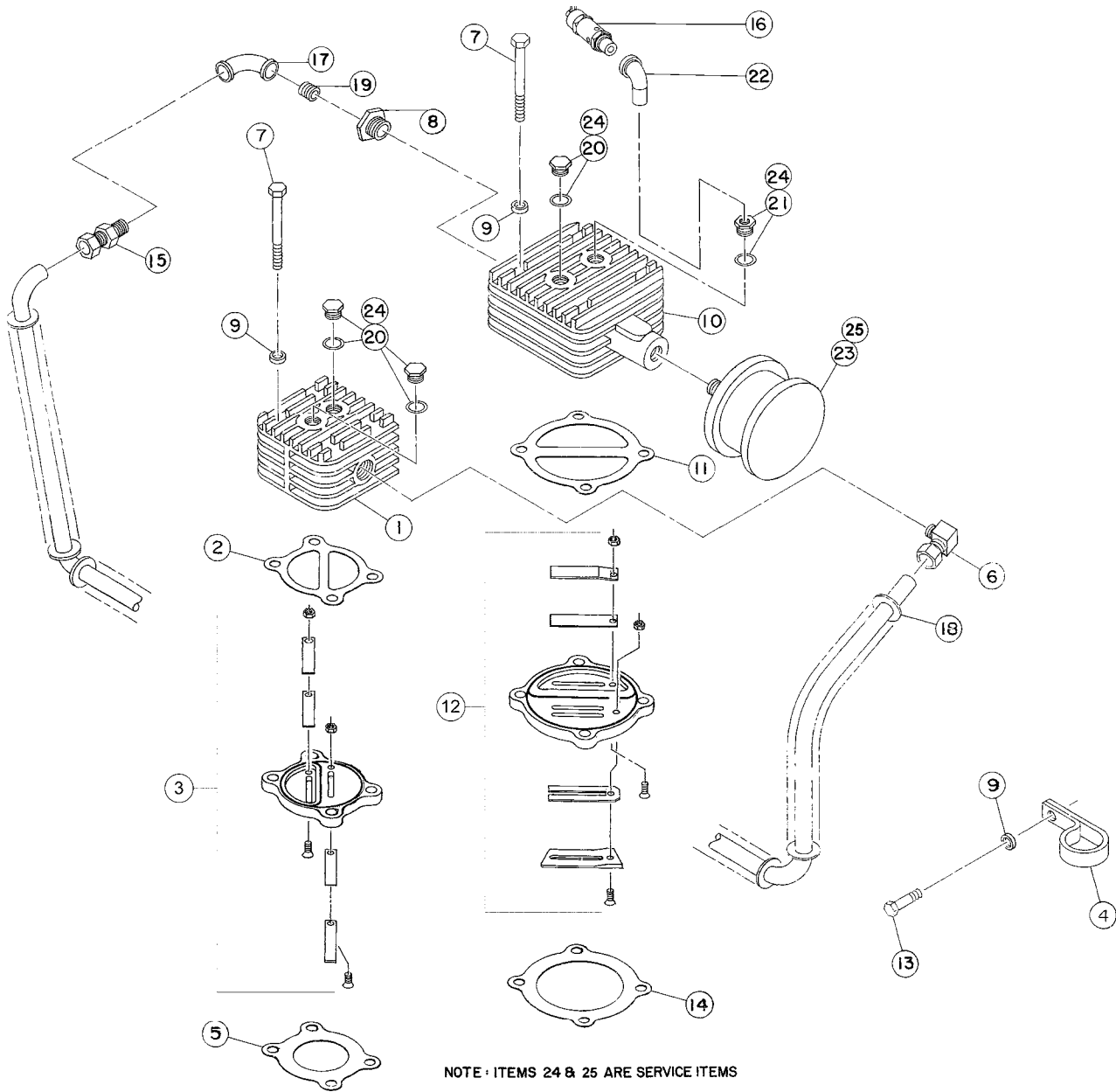

HEAD GROUP 111935-1

(*right bank / less head unloaders)

Item Number	Qty.	Part Number	Description
1	1	111115-5	cylinder head, high pressure
2	1	111274-001	gasket, head to valve plate
3	1	111227X2	valve plate assembly, high pressure
4	1	112225-2	tube clamp
5	1	111228-004	gasket, cylinder to valve plate
6	1	110919-024	tube fitting, 90° male elbow, 3/4 tube x 3/4 npt
7	8	123478-L25	hex. screw, 3/8-16 unc x 4.00, grade 5 (@ 30 ft.-lbs.)
8	1	2392	pipe bushing, 1 npt x 3/4 npt
9	9	110428N038	flatwasher, 3/8
10	1	111118-4	cylinder head, low pressure
11	1	111229-001	gasket, head to valve plate
12	1	111226X2M	valve plate assembly, low pressure
13	1	115037-L12	hex. screw, 3/8-16 unc x 1.00, grade 5 w/ sealant (@ 30 ft.-lbs.)
14	1	111228-003	gasket, cylinder to valve plate
15	1	23271	tube fitting, straight 3/4 tube x 3/4 npt
16	1	2961-100	safety valve
17	1	4816	pipe elbow, 3/4 npt
18	1	112130	intercooler (N.S.S.; order Intercooler Replacement Kit)
19	1	125936-009	pipe nipple, 3/4 npt x 1.88
20	3	112709-006	plug, 3/4-16 unf ("o"ring included)
21	1	112710-004	adapter, 3/4-16 unf x 1/4 npt ("o"ring included)
22	1	111146F100	air filter
	or		
22	1	111550S100	air filter/silencer, hooded
Maintenance Parts			
23	4	112708-908	"o"ring, silicone
24	1	111146E100	air filter element, (fits 111146F100 filter)
	or		
24	1	110377E100	air filter element, (fits 111550S100 filter/silencer)
	1	112713M15	Valve Assembly Replacement Kit, LP includes valve plate assembly & gaskets
	1	112714	Valve Assembly Replacement Kit, HP includes valve plate assembly & gaskets
	1	112130K	Intercooler Replacement Kit includes intercooler and nut/sleeve fittings

*As viewed facing the compressor from the sheave side.

N.S.S. = Not Sold Separate

@ Indicates torque value (dry threads)

Note: Tighten all bolts & capscrews in any bolt pattern, evenly bringing each bolt to torque in equal increments, while moving about the bolt pattern. This is particularly true of connecting rod & head bolts.

HEAD GROUP 111936-1

(*left bank / less head unloaders)

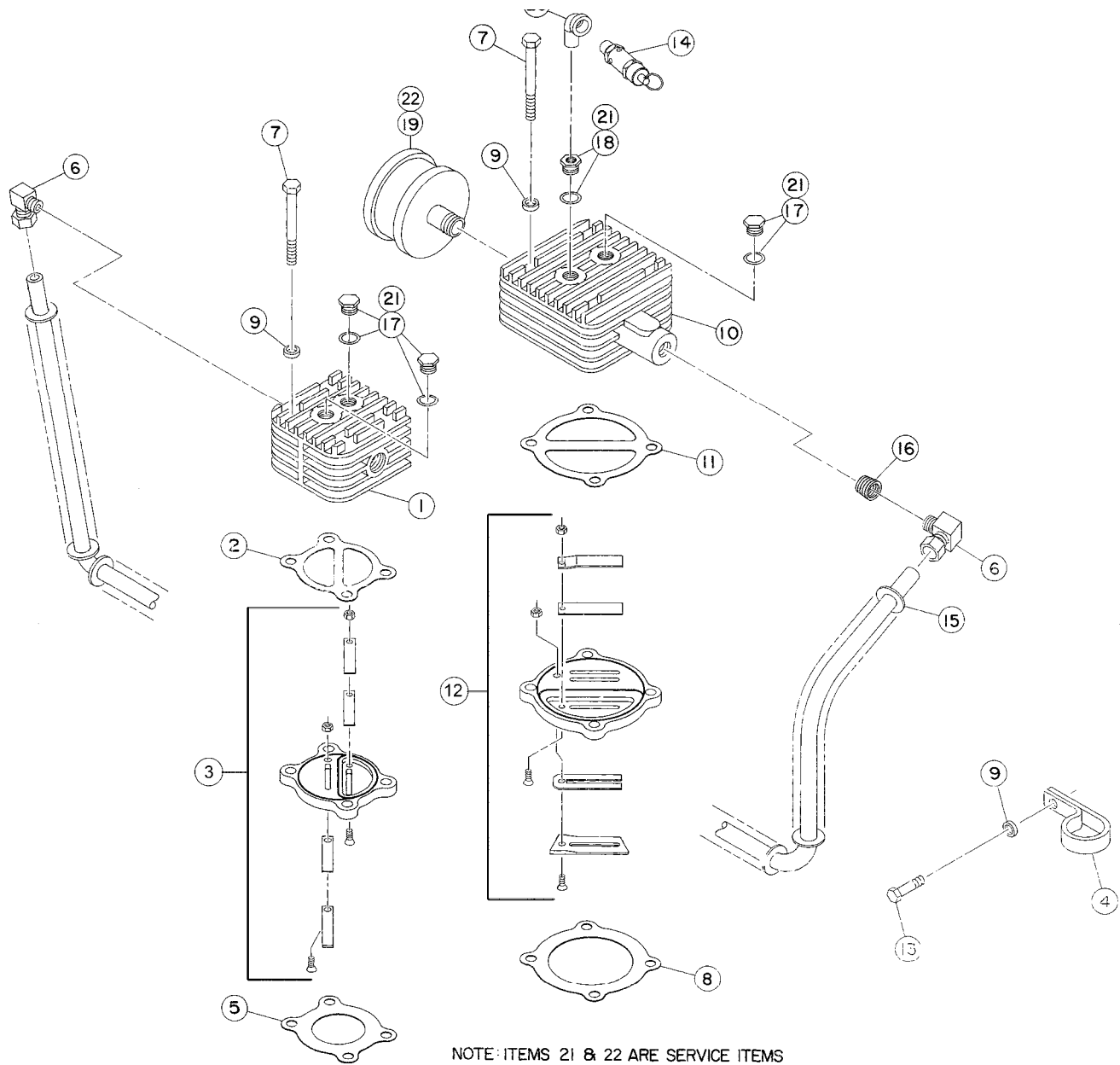

HEAD GROUP 111936-1

(*left bank / less head unloaders)

Item Number	Qty.	Part Number	Description
1	1	111115-5	cylinder head, high pressure
2	1	111274-001	gasket, head to valve plate
3	1	111227X2	valve plate assembly, high pressure
4	1	112225-2	tube clamp
5	1	111228-004	gasket, cylinder to valve plate
6	2	110919-024	tube fitting, 90° male elbow, 3/4 tube x 3/4 npt
7	8	123478-L25	hex. screw, 3/8-16 unc x 4.00, grade 5 (@ 30 ft.-lbs.)
8	1	111228-003	gasket, cylinder to valve plate
9	9	110428N038	flatwasher, 3/8
10	1	111118-4	cylinder head, low pressure
11	1	111229-001	gasket, head to valve plate
12	1	111226X2M	valve plate assembly, low pressure
13	1	115037-L12	hex. screw, 3/8-16 unc x 1.00, grade 5 w/ sealant (@ 30 ft.-lbs.)
14	1	2961-100	safety valve
15	1	112129	intercooler (N.S.S.; order Intercooler Replacement Kit)
16	1	112825-002	pipe bushing, 1 npt x 3/4 npt
17	3	112709-006	plug, 3/4-16 unf ("o"ring included)
18	1	112710-004	adapter, 3/4-16 unf x 1/4 npt ("o"ring included)
19	1	111146F100	air filter
		or	
19	1	111550S100	air filter/silencer, hooded
Maintenance Parts			
20	4	112708-908	"o"ring, silicone
21	1	111146E100	air filter element, (fits 111146F100 filter)
		or	
21	1	110377E100	air filter element, (fits 111550S100 filter/silencer)
	1	112713M15	Valve Assembly Replacement Kit, LP includes valve plate assembly & gaskets
	1	112714	Valve Assembly Replacement Kit, HP includes valve plate assembly & gaskets
	1	112129K	Intercooler Replacement Kit includes intercooler and nut/sleeve fittings

*As viewed facing the compressor from the sheave side.

N.S.S. = Not Sold Separate

@ Indicates torque value (dry threads)

Note: Tighten all bolts & capscrews in any bolt pattern, evenly bringing each bolt to torque in equal increments, while moving about the bolt pattern. This is particularly true of connecting rod & head bolts.

HEAD GROUP 112037-1

(*right bank / with head unloaders)

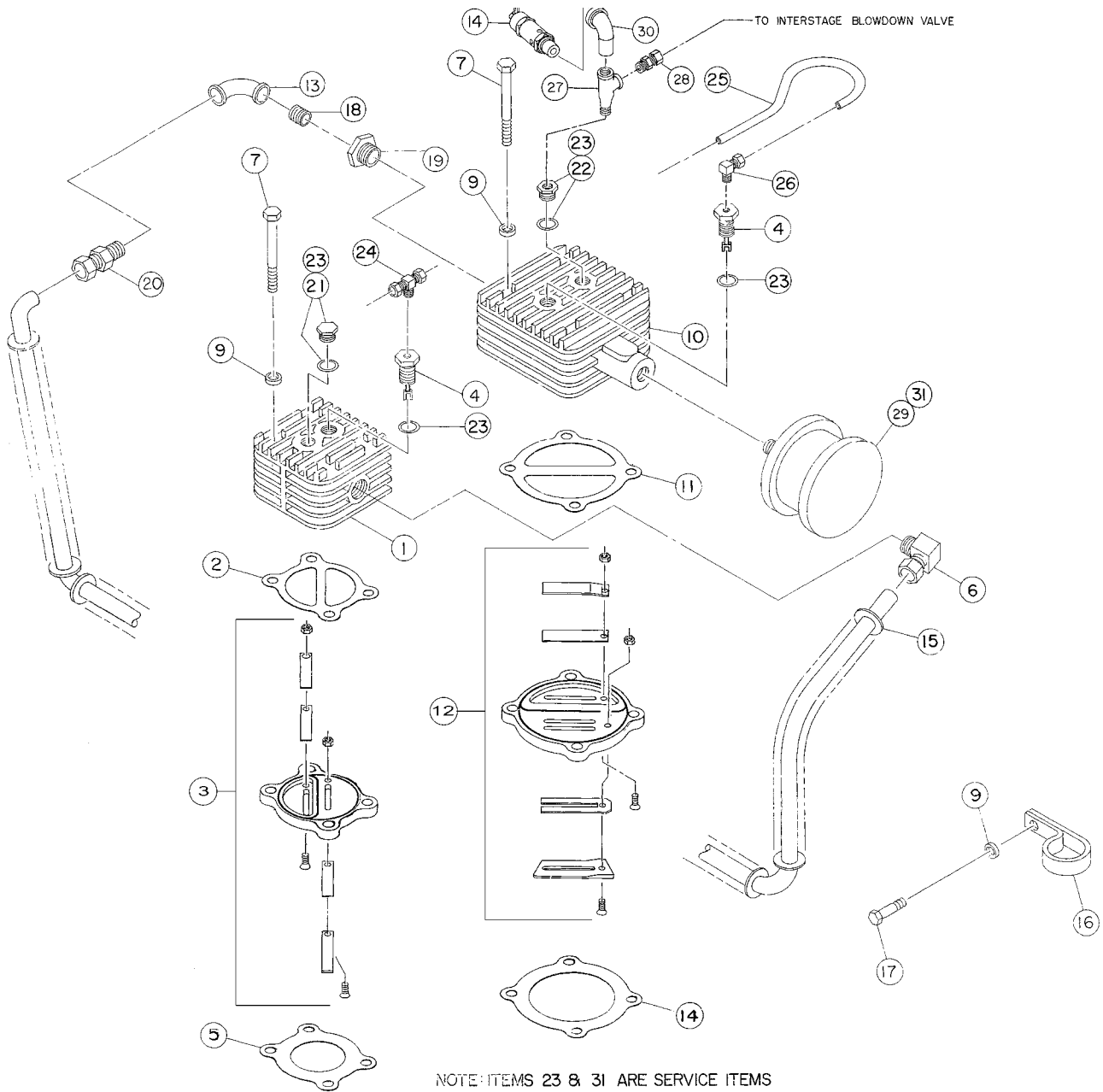

HEAD GROUP 112037-1

(*right bank / with head unloaders)

Item Number	Qty.	Part Number	Description
1	1	111115-5	cylinder head, high pressure
2	1	111274-001	gasket, head to valve plate
3	1	111227X2	valve plate assembly, high pressure
4	2	111591X1	unloader
5	1	111228-004	gasket, cylinder to valve plate
6	1	110919-024	tube fitting, 90° male elbow, 3/4 tube x 3/4 npt
7	8	123478-L25	hex. screw, 3/8-16 unc x 4.00, grade 5 (@ 30 ft.-lbs.)
8	1	111228-003	gasket, cylinder to valve plate
9	9	110428N038	flatwasher, 3/8
10	1	111118-4	cylinder head, low pressure
11	1	111229-001	gasket, head to valve plate
12	1	111226X2M	valve plate assembly, low pressure
13	1	4816	pipe elbow, 3/4 npt
14	1	2961-100	safety valve
15	1	112130	intercooler (N.S.S.; order Intercooler Replacement Kit)
16	1	112225-2	tube clamp
17	1	115037-L12	hex. screw, 3/8-16 unc x 1.00, grade 5 w/ sealant (@ 30 ft.-lbs.)
18	1	125936-009	pipe nipple, 3/4 npt x 1.88
19	1	2392	pipe bushing, 1 npt x 3/4 npt
20	1	23271	tube fitting, straight 3/4 tube x 3/4 npt
21	1	112709-006	plug, 3/4-16 unf ("o"ring included)
22	1	112710-004	adapter, 3/4-16 unf x 1/4 npt ("o"ring included)
23	2	112708-908	"o"ring, silicone
24	1	124351-004	tube fitting, male branch tee, 1/4 tube x 1/4 npt
25	1	110515-025	copper tube, 1/4 o.d.
26	1	2708	tube fitting, 90° male elbow, 1/4 tube x 1/4 npt
27	1	3003	pipe tee, 1/4 npt x 1/4 npt x 1/4 npt
28	1	110594-005	tube fitting, male connector, 1/4 tube x 1/4 npt
29	1	110377F100	air filter
		or	
29	1	111550S100	air filter/silencer, hooded
			Maintenance Parts
30	1	110377E100	air filter element, (fits 110377F100 air filter and 111550S100 filter/silencer)
	1	112713M15	Valve Assembly Replacement Kit, LP includes valve plate assembly & gaskets
	1	112714	Valve Assembly Replacement Kit, HP includes valve plate assembly & gaskets
	1	112130K	Intercooler Replacement Kit includes intercooler and nut/sleeve fittings

*As viewed facing the compressor from the sheave side.

N.S.S. = Not Sold Separate

@ Indicates torque value (dry threads)

Note: Tighten all bolts & capscrews in any bolt pattern, evenly bringing each bolt to torque in equal increments, while moving about the bolt pattern. This is particularly true of connecting rod & head bolts.

HEAD GROUP 112038-1

(*left bank / with head unloaders)

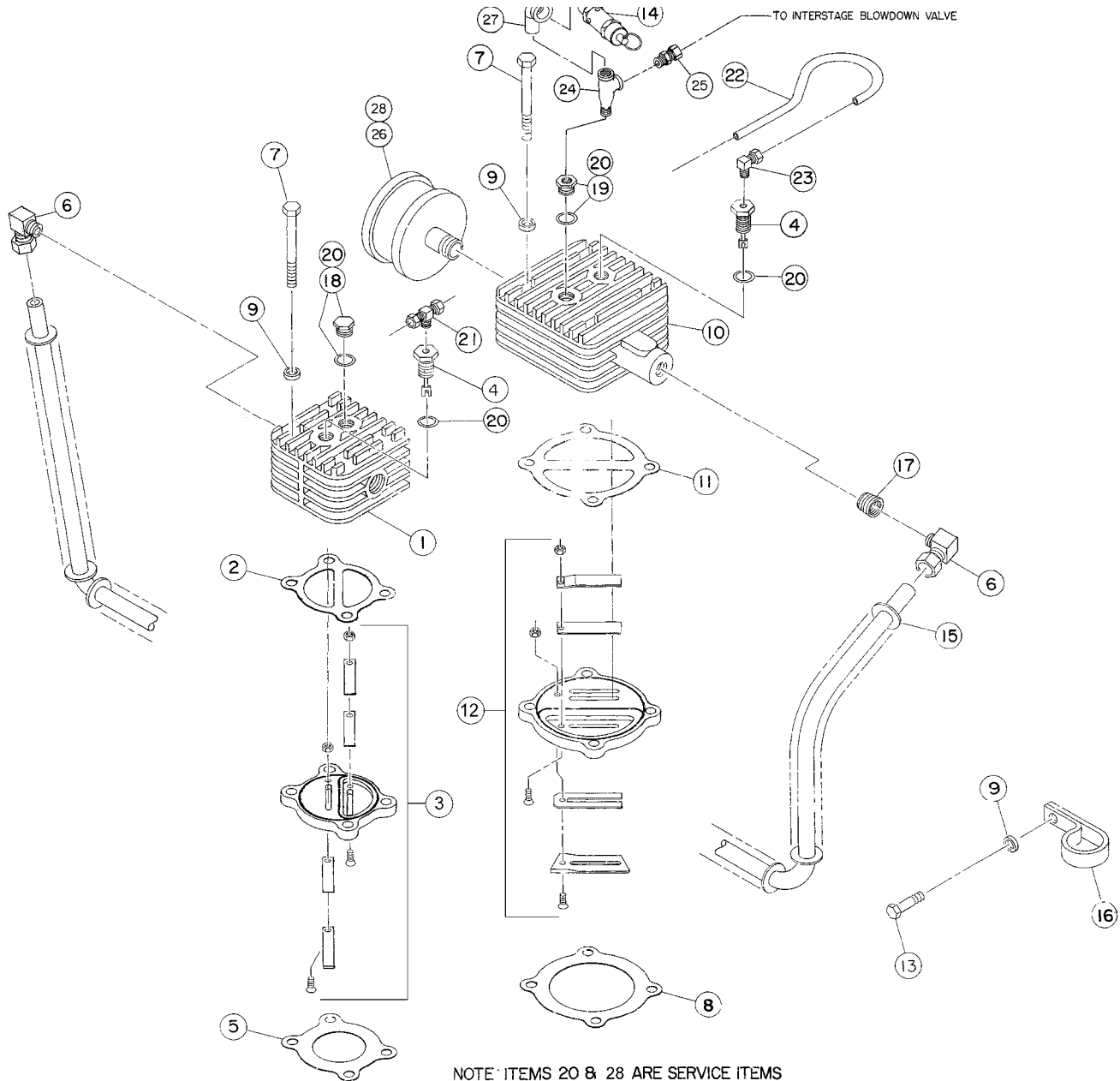

HEAD GROUP 112038-1

(*left bank / with head unloaders)

Item Number	Qty.	Part Number	Description
1	1	111115-5	cylinder head, high pressure
2	1	111274-001	gasket, head to valve plate
3	1	111227X2	valve plate assembly, high pressure
4	2	111591X1	unloader
5	1	111228-004	gasket, cylinder to valve plate
6	2	110919-024	tube fitting, 90° male elbow, 3/4 tube x 3/4 npt
7	8	123478-L25	hex. screw, 3/8-16 unc x 4.00, grade 5 (@ 30 ft.-lbs.)
8	1	111228-003	gasket, cylinder to valve plate
9	9	110428N038	flatwasher, 3/8
10	1	111118-4	cylinder head, low pressure
11	1	111229-001	gasket, head to valve plate
12	1	111226X2M	valve plate assembly, low pressure
13	1	115037-L12	hex. screw, 3/8-16 unc x 1.00, grade 5 w/ sealant (@ 30 ft.-lbs.)
14	1	2961-100	safety valve
15	1	112129	intercooler (N.S.S.; order Intercooler Replacement Kit)
16	1	112225-2	tube clamp
17	1	112825-002	pipe bushing, 1 npt x 3/4 npt
18	1	112709-006	plug, 3/4-16 unf ("o"ring included)
19	1	112710-004	adapter, 3/4-16 unf x 1/4 npt ("o"ring included)
20	2	112708-908	"o"ring, silicone
21	1	124351-004	tube fitting, male branch tee, 1/4 tube x 1/4 npt
22	1ft	110515-025	copper tube, 1/4 o.d.
23	1	2708	tube fitting, 90° male elbow, 1/4 tube x 1/4 npt
24	1	3003	pipe tee, 1/4 npt x 1/4 npt x 1/4 npt
25	1	110594-005	tube fitting, 1/4 tube x 1/4 npt
26	1	110377F100	air filter
	or		
26	1	111550S100	air filter/silencer, hooded
Maintenance Parts			
27	1	110377E100	air filter element, (fits 110377F100 air filter and 111550S100 filter/silencer)
	1	112713M15	Valve Assembly Replacement Kit, LP includes valve plate assembly & gaskets
	1	112714	Valve Assembly Replacement Kit, HP includes valve plate assembly & gaskets
	1	112129K	Intercooler Replacement Kit includes intercooler and nut/sleeve fittings

*As viewed facing the compressor from the sheave side.

N.S.S. = Not Sold Separate

@ Indicates torque value (dry threads)

Note: Tighten all bolts & capscrews in any bolt pattern, evenly bringing each bolt to torque in equal increments, while moving about the bolt pattern. This is particularly true of connecting rod & head bolts.

MANIFOLD GROUP 112257

Item Number	Qty.	Part Number	Description
1	1	110919-024	tube fitting, 90° male elbow, 3/4 tube x 3/4 npt
2	2ft	110515-075	copper tube, 3/4 OD
3	1	23271	tube fitting, straight 3/4 tube x 3/4 npt
4	1	122082	pipe tee, 1 npt x 3/4 npt x 3/4 npt
5	1	124689-001	pipe nipple, 3/4 npt x close
6	1	22238	pipe elbow, 45°, 1 npt
7	1	6101	pipe nipple, 1 npt x close

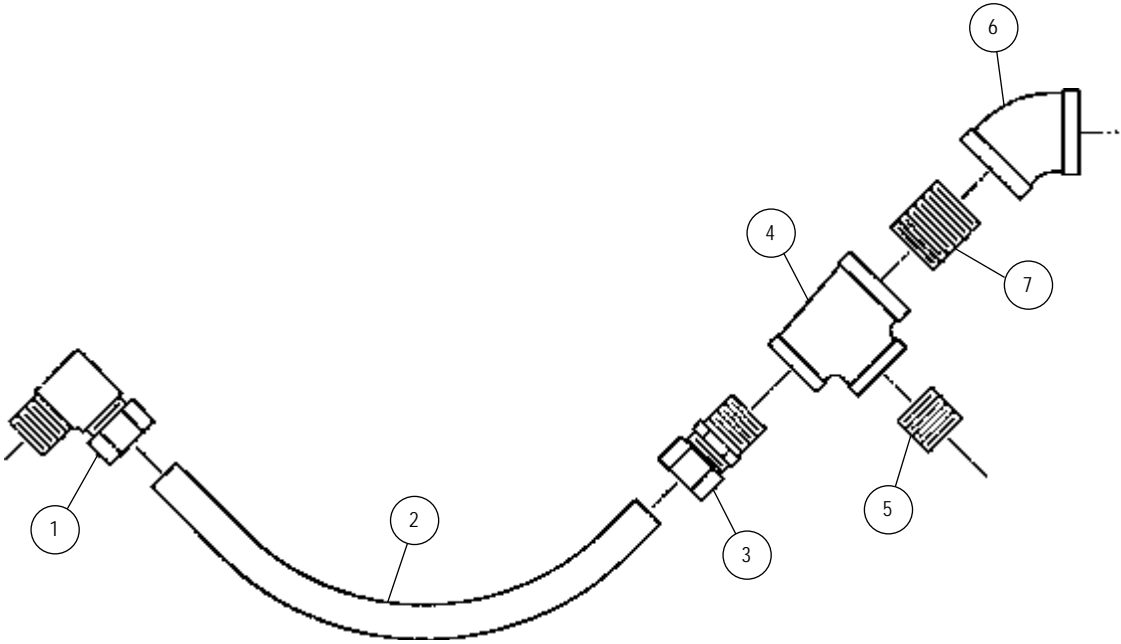

CONTROL PIPING SCHEMATICS

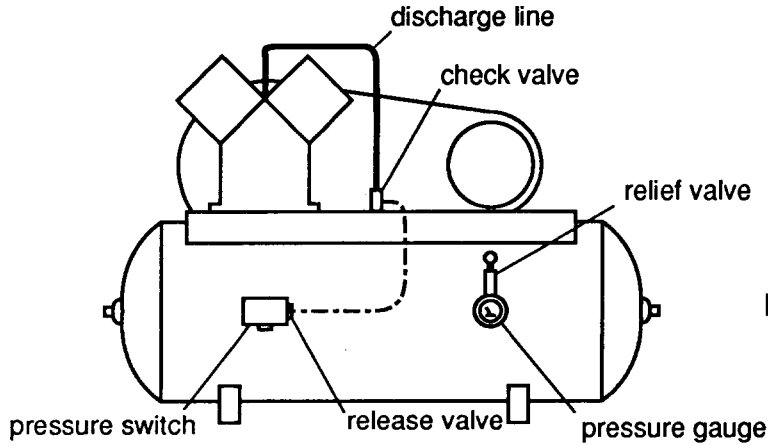

**Control Piping
For Automatic Start/Stop
Operation**

(with loadless starting)

**Control Piping
For Continuous Run
Operation**

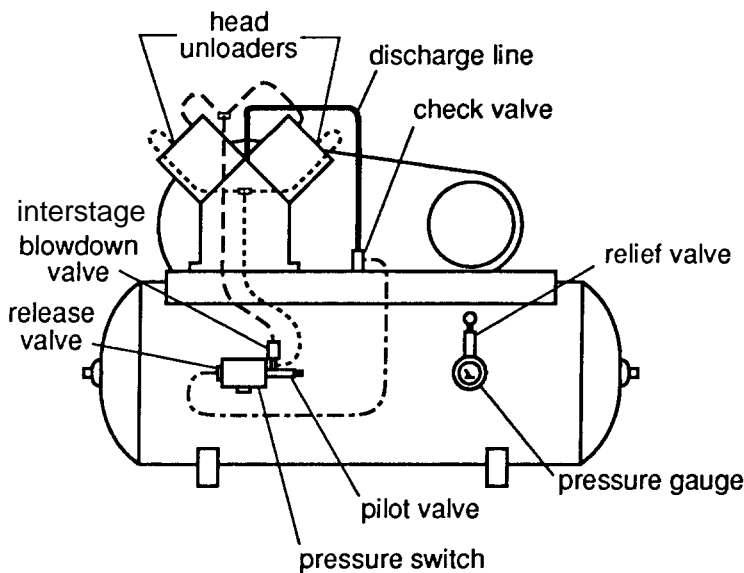
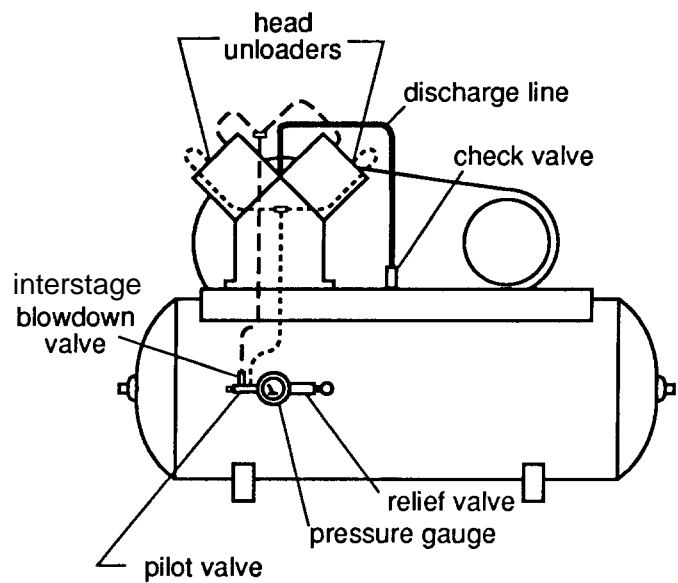

**Control Piping
For Dual Control
Operation**

*Pilot valve is open (stem screwed out)
for Continuous Run operation*

*Pilot valve is closed (stem screwed in)
for automatic Start/Stop operation
(with loadless starting)*

PILOT VALVES

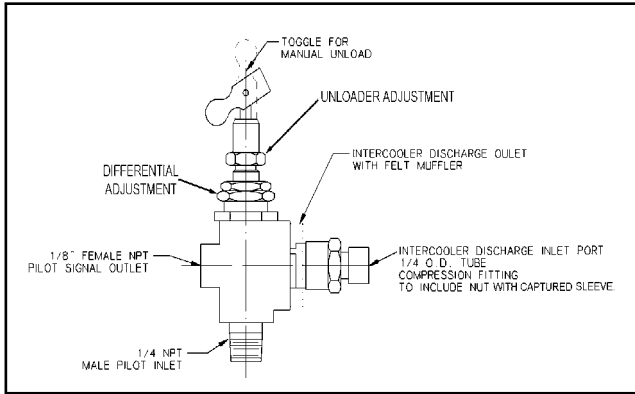

**113321 series pilot valve
(continuous run operation)**

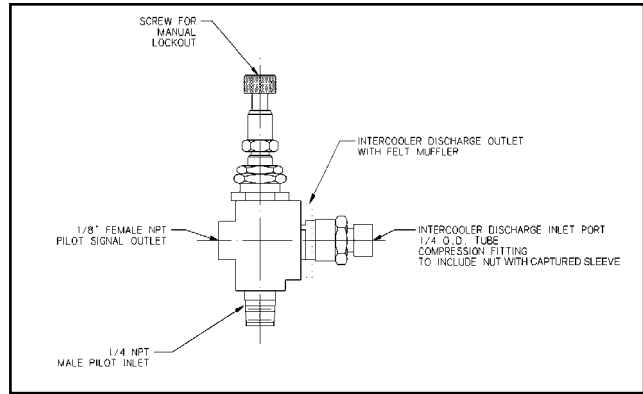

**113320 series pilot valve
(dual control operation)**

Available 113321 Series Pilot Valves	
Pilot Valve	Pressure Setting
113321-090	80-90
113321-100	90-100
113321-110	100-110
113321-125	110-125
113321-140	130-140
113321-150	135-150
113321-165	150-165

Available 113320 Series Pilot Valves	
Pilot Valve	Pressure Setting
113320-095	75-95
113320-115	100-115
113320-140	125-140
113320-165	150-165

WARNING !
 Not all pilots are for use with all compressor systems. Make sure that the pilot you order is set within the safe operating limits of your compressor. Failure to heed this warning could result in an explosion.

Differential Setting Chart		
<i>Applies to 113320 & 113321 series pilot valves</i>		
Unload (PSI)	Min. Dif. (PSI)	Max. Dif. (PSI)
40	2	5
60	3	10
100	4	20
150	5	30
175	5	45

Pilot Valve Repair Kit 113320K	
<i>Can be used to repair 113320 & 113321 series pilot valves</i>	
Qty.	Part Description
1	ball
1	"o"ring
1	piston
1	diaphragm
1	pilot spring
1	piston spring
1	toggle lever
1	rivet
1	muffler
1	retaining ring

SUCTION VALVE UNLOADER ASSEMBLIES

Description

The Quincy suction valve unloader assembly consists of unloading assemblies on the suction valves, having a plunger to contact the suction valve reed and an unloader pilot valve (113320 or 113321 series) to automatically regulate the passing of air tank pressure to the unloading arrangement.

Continuous Run Operation

Suction valve unloader assemblies are recommended for use on Quincy compressors where the compressor is to run continuously and a constant pressure is to be maintained. The purpose is to automatically unseat the suction valve of the compressor when the air supply is greater than the demand.

Unloading occurs when air tank pressure is sufficient to overcome pilot valve spring pressure. The check ball is then unseated, allowing air tank pressure to pass to the unloader assemblies. The compressor will run unloaded until the air tank pressure drops to a predetermined level. At this time, the action of the ball is reversed, shutting off air tank pressure to the unloader assemblies and venting the unloader to atmosphere. This allows the compressor to load. The drive, either electric motor or engine, runs continuously and must be started and stopped manually. 113321 series pilot valves feature a toggle lever which can be flipped to provide manual unloading.

Dual Control Operation

Dual control operation is designed to provide a choice between "start/stop" or "continuous run" operation. The 113320 series pilot valve can be set for "start/stop" operation by turning the knurled knob at the end of the pilot valve (*refer to illustration for 113320 series pilot valve*) clockwise until it stops. Under these circumstances, a pressure switch is required to stop the motor. Failure to use a pressure switch, with the pilot valve locked out, will result in unsafe conditions.

WARNING !

A pressure switch must be incorporated whenever 113320 series pilot valve is employed as part of the control system.

The compressor will operate in the continuous run mode if the knurled knob is turned counterclockwise until it stops.

Interstage Blowdown Valve

113320 & 113321 series pilot valves feature an interstage blowdown valve which bleeds interstage pressure back to atmosphere when the compressor is running unloaded. This reduces the unloaded horsepower.

Installation

The pilot valve is mounted directly into the air tank. Compressors in the field, not equipped with these controls, can be converted. Consult your local Quincy distributor for assistance with conversion procedures.

Service

If a change in pilot valve operation is detected, remove the pilot valve from the air tank and check the screen in the inlet of the pilot valve for obstructions. Clean the screen if necessary.

Adjustment

The unloading pressure is adjustable and is regulated by turning the unload adjustment hex nut (*refer to pilot valve illustrations*). Turn the hex nut clockwise to increase and counterclockwise to decrease the unloading pressure.

The differential (difference between unloading and loading pressure) is set by turning the differential adjustment hex nut (*refer to pilot valve illustrations*). Increase the differential pressure by turning the hex nut clockwise - decrease by turning counterclockwise. Make all adjustments in small increments. Tighten the locknuts after adjustment.

DECALS

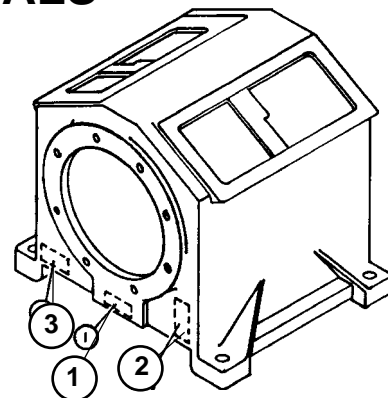

Decals			
Item #	Qty.	Part Number	Description
1	1	110831	serial number & nameplate
2	1	127889-A	decal, CAUTION!, MANUAL
3	1	127889-B	decal, DANGER!, "Air from this...."

Overhaul Kit KQT15H (for models with head unloaders)			
Item #	Qty.	Part Number	Description
2		115814	piston ring set
2		115815	piston ring set
1		112085	gasket set
2		111227X2	valve plate assembly, HP
2		111226X2M	valve plate assembly, LP
2		110377E100	air filter, element
2		110190-052	piston pin assembly, LP
2		110190-053	piston pin assembly, HP
2		115590-001	connecting rod assembly
2		111927-003	connecting rod assembly
1		111333	breather filter
2		115564	dipper screw
2		110428N031	washer

Head Kit KQT15B (for models without head unloader)			
Item #	Qty.	Part Number	Description
2		112713M15	valve assembly kit, LP
2		112714	valve assembly kit, HP
2		111146E100	air filter element, (fits 111146F100 filter)

Head Kit KQT15D (for models with head unloader)			
Item #	Qty.	Part Number	Description
2		112713M15	valve assembly kit, LP
2		112714	valve assembly kit, HP
2		110377E100	air filter element, (fits 110377S100 filter)

Recommended Spare Parts			
Item #	Qty.	Part Number	Description
1		110377E100	air filter element
or			
1		111146E100	air filter element
1		112085	gasket set
1		111226X2M	valve plate assembly, LP
1		111227X2	valve plate assembly, HP

Gasket Set 112085			
Item #	Qty.	Part Number	Description
1		111781-001	oil seal
2		111274-001	gasket, head to valve plate
2		111229-001	gasket, head to valve plate
2		111228-003	gasket, cylinder to valve plate
2		111228-004	gasket, cylinder to valve plate
1		22749-167	"o"ring, 3/32 wide x 7.19 o.d.
1		123157-112	"o"ring, 3/32 wide x .69 o.d.
2		111782	gasket, cylinder to crankcase
8		112708-908	"o"ring, silicone

TYPICAL UNIT REPAIR PARTS LIST

The parts listed here are for standard QT-15 units and may or may not be applicable to custom built units. Check with your local authorized Quincy distributor for parts that can be used for custom built units. Make sure the components you order are rated within the safe operating limits of your system. If you are doubtful about which components to order, contact your local Quincy distributor.

(QT-15 simplex - horizontal tank - electric motor)

Qty	Part Number	Part Number	Part Number	Description
	80 gal.	120 gal.	200 gal.	
1	113269-200	113272-200	113273-200	tank
1	113277	n/a	<i>113282-001</i>	top plate
1	2713	111136-050	111136-050	tank drain valve
1	111136-100	111136-100	111136-100	service valve
1	110514-300	110514-300	110514-200	pressure gauge
1	110512-005	110512-005	110512-005	pressure switch, 135-175 PSI
1	110513-200	110513-200	110513-200	pressure relief valve, 200 PSI (in tank)
1	2961-215	2961-215	2961-215	pressure relief valve, 215 PSI (in discharge line)
1	114800-100	114800-100	114800-100	check valve
1	114559-003	114559-003	114559-003	discharge tube
2	111265-100	111265-100	111265-100	ferrule/sleeve
	10 h.p.	15 h.p.		
2	<i>110258B094</i>	<i>110258B098</i>		drive belt
1	<i>8458</i>	<i>116378</i>		motor pulley
1	<i>5380</i>	<i>8936</i>		bushing
1	<i>112432K003</i>	<i>112432K003</i>		belt guard assembly
	200v, 3Ø	230/460v, 3Ø		
1	<i>40656</i>	<i>4014</i>		10 h.p. motor (ODP)
1	<i>40657</i>	<i>127466L042</i>		15 h.p. motor (ODP)

(QT-15 duplex - horizontal tank - electric motor)

Qty	Part Number	Part Number	Part Number	Description
	200 gal.	240 gal.		
1	113468-200	113470-200		tank
2	<i>113282-001</i>	<i>113282-001</i>		top plate
1	111136-050	111136-050		tank drain valve
1	111136-075	111136-100		service valve
1	110514-300	110514-300		pressure gauge
2	110512-005	110512-005		pressure switch, 135-175 PSI
1	110513-200	110513-200		pressure relief valve, 200 PSI (in tank)
2	2961-215	2961-215		pressure relief valve, 215 PSI (in discharge line)
2	114800-100	114800-100		check valve
2	114559-003	114559-003		discharge tube
4	111265-100	111265-100		ferrule/sleeve
	10 h.p.	15 h.p.		
4	<i>110258B094</i>	<i>110258B098</i>		drive belt
2	<i>8458</i>	<i>116378</i>		motor pulley
2	<i>5380</i>	<i>8936</i>		bushing
2	<i>112432K003</i>	<i>112432K003</i>		belt guard assembly
	200v, 3Ø	230/460v, 3Ø		
2	<i>40656</i>	<i>4014</i>		10 h.p. motor (ODP)
2	<i>40657</i>	<i>127466L042</i>		15 h.p. motor (ODP)

Part numbers shown in italics apply to tank mounted units and base mounted units.

TYPICAL UNIT REPAIR PARTS LIST

The parts listed here are for standard QT-15 units and may or may not be applicable to custom built units. Check with your local authorized Quincy distributor for parts that can be used for custom built units. Make sure the components you order are rated within the safe operating limits of your system. If you are doubtful about which components to order, contact you local Quincy distributor.

(QT-15 gasoline engine driven)

Qty	Part Number	Part Number	Part Number	Description
	base unit	tank unit		
1		113716-200		tank, 200 psi
1	113717	113717		top plate
1		111136-025		tank drain valve
1		111136-075		ball valve
1		110514-300		pressure gauge
1		110513-200		pressure relief valve, 200 PSI (in tank)
1	115560B090	115560B090		drive belt
1	110622	110622		engine pulley
1	8924	8924		engine pulley bushing
1	112432-003	112432-003		belt guard assembly
1	113143-004	113143-004		throttle control
1	113720-001	113720		Kohler engine group, 18 h.p. (includes exhaust system & throttle control)
2 ft.		110515-100		! discharge tube (1" copper tube to be formed by customer)
2		111265-100		ferrule / sleeve
1	114800-100	114800-100		check valve
1	2961-215	2961-215		pressure relief valve, 215 PSI (discharge line)
1	112316	112316		fuel tank group, 6 gal. (incl. fuel tank & 6 ft. of hose)
1	113708-175	113708-175		pilot, 165-175 PSI

! Pre-formed discharge tubes are available. Contact factory with model & tank size information.

QUINCY COMPRESSOR

STANDARD TERMS AND CONDITIONS

LEGAL EFFECT: Except as expressly otherwise agreed to in writing by an authorized representative of Seller, the following terms and conditions shall apply to and form a part of this order and any additional and/or different terms of Buyer's purchase order or other form of acceptance are rejected in advance and shall not become a part of this order.

The rights of Buyer hereunder shall be neither assignable nor transferable except with the written consent of Seller.

This order may not be canceled or altered except with the written consent of Seller and upon terms which will indemnify Seller against all loss occasioned thereby. All additional costs incurred by Seller due to changes in design or specifications, modification of this order or revision of product must be paid for by Buyer.

In addition to the rights and remedies conferred upon Seller by this order, Seller shall have all rights and remedies conferred at law and in equity and shall not be required to proceed with the performance of this order if Buyer is in default in the performance of such order or of any other contract or order with seller.

TERMS OF PAYMENT: Unless otherwise specified in the order acknowledgment, the terms of payment shall be 1% 15, net forty-five (45) days after shipment. These terms shall apply to partial as well as complete shipments. If any proceeding be initiated by or against Buyer under any bankruptcy or insolvency law, or in the judgment of Seller the financial condition of Buyer, at the time the equipment is ready for shipment, does not justify the terms of payment specified, Seller reserves the right to require full payment in cash prior to making shipment. If such payment is not received within fifteen (15) days after notification of readiness for shipment, Seller may cancel the order as to any unshipped item and require payment of its reasonable cancellation charges.

If Buyer delays shipment, payments based on date of shipment shall become due as of the date when ready for shipment. If Buyer delays completion of manufacture, Seller may elect to require payment according to percentage of completion. Equipment held for Buyer shall be at Buyer's risk and storage charges may be applied at the discretion of Seller.

Accounts past due shall bear interest at the highest rate lawful to contract for but if there is no limit set by law, such interest shall be eighteen percent (18%). Buyer shall pay all cost and expenses, including reasonable attorney's fees, incurred in collecting the same, and no claim, except claims within Seller's warranty of material or workmanship, as stated below, will be recognized unless delivered in writing to Seller within thirty (30) days after date of shipment.

TAXES: All prices exclude present and future sales, use, occupation, license, excise, and other taxes in respect of manufacture, sales or delivery, all of which shall be paid by Buyer unless included in the purchase price at the proper rate or a proper exemption certificate is furnished.

ACCEPTANCE: All offers to purchase, quotations and contracts of sales are subject to final acceptance by an authorized representative at Seller's plant.

DELIVERY: Except as otherwise specified in this quotation, delivery will be F. O. B. point of shipment. In the absence of exact shipping instruction, Seller will use its discretion regarding best means of insured shipment. No liability will be accepted by Seller for so doing. All transportation charges are at Buyer's expense. Time of delivery is an estimate only and is based upon the receipt of all information and necessary approvals. The shipping schedule shall not be construed to limit seller in making commitments for materials or in fabricating articles under this order in accordance with Seller's normal and reasonable production schedules.

Seller shall in no event be liable for delays caused by fires, acts of God, strikes, labor difficulties, acts of governmental or military authorities, delays in transportation or procuring materials, or causes of any kind beyond Seller's control. No provision for liquidated damages for any cause shall apply under this order. Buyer shall accept delivery within thirty (30) days after receipt of notification of readiness for shipment. Claims for shortages will be deemed to have been waived if not made in writing with ten (10) days after the receipt of the material in respect of which any such shortage is claimed. Seller is not responsible for loss or damage in transit after having received "In Good Order" receipt from the carrier. All claims for loss or damage in transit should be made to the carrier.

TITLE & LIEN RIGHTS: The equipment shall remain personal property, regardless of how affixed to any realty or structure. Until the price (including any notes given therefore) of the equipment has been fully paid in cash, Seller shall, in the event of Buyer's default, have the right to repossess such equipment.

PATENT INFRINGEMENT: If properly notified and given an opportunity to do so with friendly assistance, Seller will defend Buyer and the ultimate user of the equipment from any actual or alleged infringement of any published United States patent by the equipment or any part thereof furnished pursuant hereto (other than parts of special design, construction, or manufacture specified by and originating with Buyer), and will pay all damages and costs awarded by competent court in any suit thus defended or of which it may have had notice and opportunity to defend as aforesaid.

STANDARD WARRANTY: Seller warrants that products of its own manufacture will be free from defects in workmanship and materials under normal use and service for the period specified in the product instruction manual. Warranty for service parts will be Ninety (90) days from date of factory shipment. Electric Motors, gasoline and diesel engines, electrical apparatus and all other accessories, components and parts not manufactured by Seller are warranted only to the extent of the original manufacturer's warranty.

Notice of the alleged defect must be given to the Seller, in writing with all identifying details including serial number, type of equipment and date of purchase within thirty (30) days of the discovery of the same during the warranty period.

Seller's sole obligation on this warranty shall be, at its option, to repair or replace or refund the purchase price of any product or part thereof which proves to be defective. If requested by Seller, such product or part thereof must be promptly returned to seller, freight prepaid, for inspection.

Seller warrants repaired or replaced parts of its own manufacture against defects in materials and workmanship under normal use and service for ninety (90) days or for the remainder of the warranty on the product being repaired.

This warranty shall not apply and Seller shall not be responsible or liable for:

(a) Consequential, collateral or special losses or damages;

(b) Equipment conditions caused by fair wear and tear, abnormal conditions of use, accident, neglect or misuse of equipment, improper storage or damage resulting during shipping;

(c) Deviation from operating instructions, specifications or other special terms of sale;

(d) Labor charges, loss or damage resulting from improper operation, maintenance or repairs made by person(s) other than Seller or Seller's authorized service station.

In no event shall Seller be liable for any claims whether arising from breach of contract or warranty or claims of negligence or negligent manufacture in excess of the purchase price.

THIS WARRANTY IS THE SOLE WARRANTY OF SELLERS AND ANY OTHER WARRANTIES, WHETHER EXPRESS OR IMPLIED IN LAW OR IMPLIED IN FACT, INCLUDING ANY WARRANTIES OF MERCHANTABILITY AND FITNESS FOR PARTICULAR USE ARE HEREBY SPECIFICALLY EXCLUDED.

LIABILITY LIMITATIONS: Under no circumstances shall the Seller have any liability for liquidated damages or for collateral, consequential or special damages or for loss of profits, or for actual losses or for loss of production or progress of construction, whether resulting from delays in delivery or performance, breach of warranty, negligent manufacture or otherwise.

ENVIRONMENTAL AND OSHA REQUIREMENTS: At the time of shipment of the equipment from the factory, Quincy Compressor / Ortman Fluid Power will comply with the various Federal, State and local laws and regulations concerning occupational health and safety and pollution. However, in the installation and operation of the equipment and other matters over which the seller has no control, the Seller assumes no responsibility for compliance with those laws and regulations, whether by the way of indemnity, warranty or otherwise.

June 30, 2003



Reciprocating / Systems: 217.222.7700
E-mail: info@quincycompressor.com
Website: quincycompressor.com

