



Atlas Copco



Oil-injected rotary screw compressors

GA 7-90 VSD iPM (7-90 kW/10-125 hp)



Innovating for a sustainable future

At Atlas Copco, we have always looked ahead. Which products and services will make our customers more successful? Your future drives the Atlas Copco team every day. It is the reason why we devote so much time and so many resources to innovation. If there are technologies that will advance your productivity, we will find them. That is what we have been doing for almost 150 years now, setting new standards in compressed air reliability, efficiency, connectivity, and sustainability.

It's that last principle that now comes first. Sustainability is no longer something we should strive for, but something we must achieve. Productivity and growth will have to be built on sustainability. Atlas Copco – our products, our services, and our people – will help you get there, as we always have.

The technology that drives sustainability



Neos inverter

In-house developed by Atlas Copco, the Neos helps ensure up to 35% energy savings and a significantly smaller environmental footprint.



iPM motor

The Interior Permanent Magnet motor was designed to give you IE4 energy efficiency and the savings to match.



Elektronikon® Touch controller

Our most advanced controller, the Elektronikon® Touch gives you the control, monitoring and optimization options that will boost your sustainable operation.

A new standard in compressor efficiency

Atlas Copco's GA 7-90 VSD iPM compressors feature a smart drive and intelligent control for unprecedented reliability and efficiency. Variable Speed Drive is integrated as standard, along with an Interior Permanent Magnet motor and a unique inverter. As a result, the GA 7-90 VSD iPM reduces energy consumption by up to 35%, setting a new benchmark for cost savings and sustainable performance in the compressor industry.

Innovative

GA 7-90 VSD iPM compressors are equipped with a horizontal leakage-free drivetrain designed by Atlas Copco. Other innovative features include its direct drive and gear drive connection, and its oil-cooled permanent magnet motor and bearing.

Smart

- Unique inverter for air compressors.
- Integrated Elektronikon® Touch controller provides advanced control, monitoring and optimization options.



Reliable

- Proven, quality components.
- Superior durability with modular design to ensure optimal integration and use of parts.
- W-fin cooler for dependable performance in harsh environments.

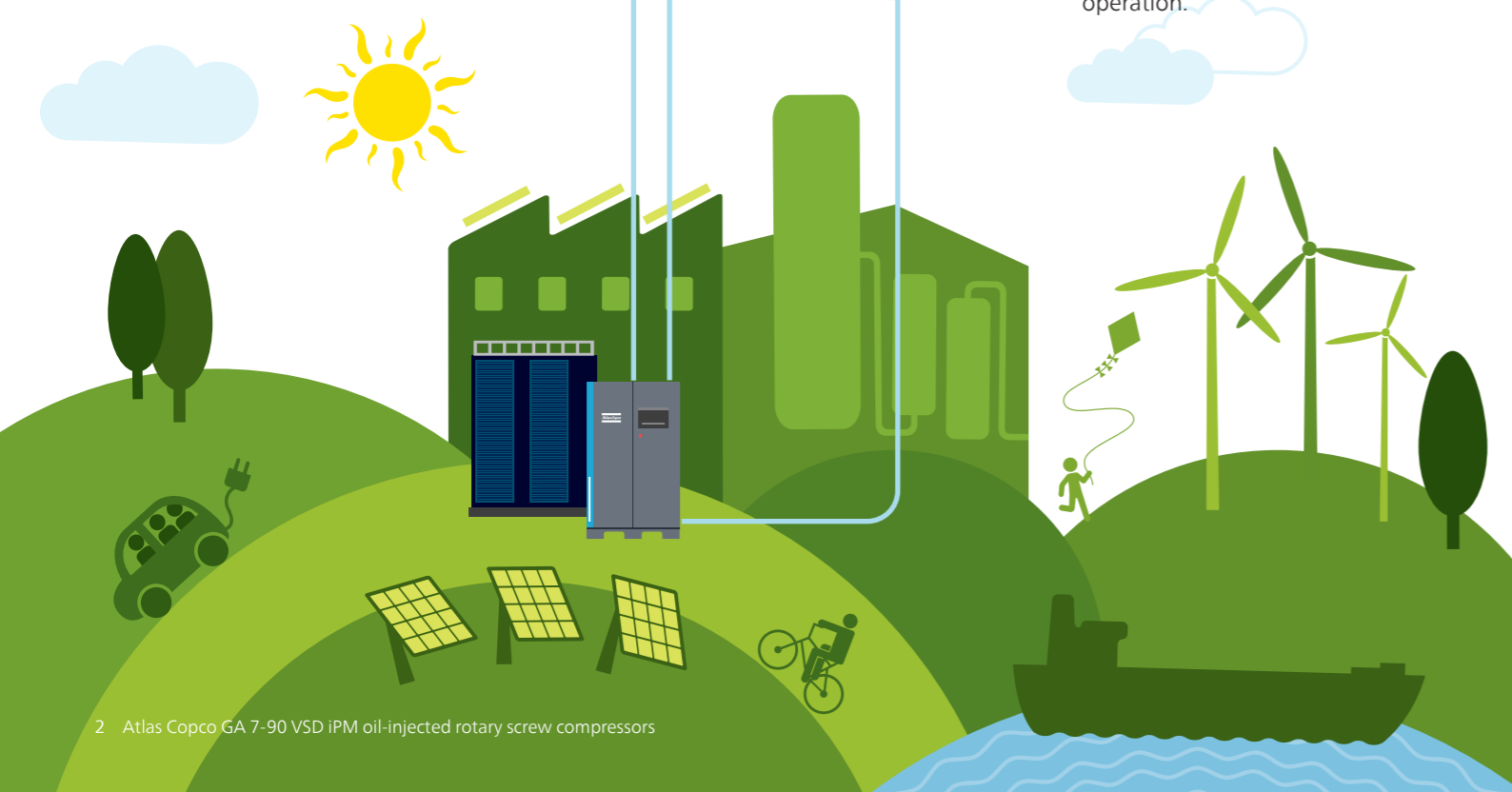

GA 7-37 VSD iPM: The smart small business compressor

Savvy small and medium-sized businesses keep their energy use low and their bottom line positive. Atlas Copco GA 7-37 VSD iPM compressors ensure those energy savings and much more. Supremely powerful and reliable, an Atlas Copco VSD iPM compressor is the ideal production floor companion.

1 Interior Permanent Magnet (iPM) motor

- Very high efficiency: equals IE4 standards
- Compact, customized design for optimal cooling by oil
- IP56 protection for GA 7-22 VSD iPM; IP66 for GA 30-37 VSD iPM.
- No cooling air flow required
- Oil-lubricated motor

2 Element

- Made by Atlas Copco
- Robust and silent
- High efficiency

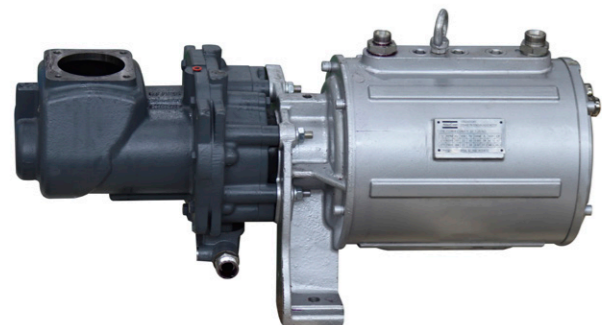

3 Direct drive

- No gears or belts
- Compact: footprint down 30%

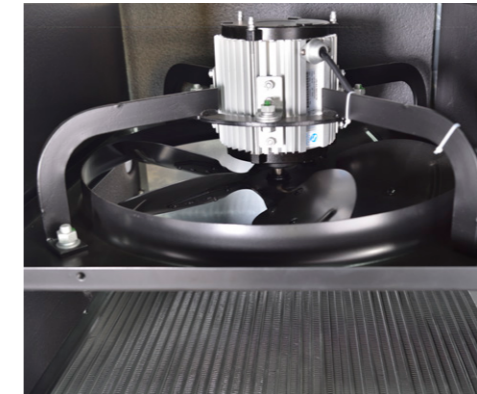

4 W-fin cooling system

- W-fin cooler is dependable in harsh conditions
- Axial fan enhances cooler performance



5 Robust oil filter/separator

- Integrated bypass valve with the oil filter
- Easy maintenance

6 Elektronikon® Touch controller

- Integrated smart algorithms reduce system pressure and energy consumption
- Warning indications, maintenance scheduling and online status visualization
- Graphic display of key parameters (day, week, month) and 32 language settings



7 Unique inverter

- Unique inverter design for air compressors
- Self-adjusting control in abnormal conditions

GA 45-90 VSD iPM: Big energy savings

Only the pioneer of Variable Speed Drive compressors can give you real VSD energy savings. Thanks to its innovative drivetrain and high-tech Neos inverter, an Atlas Copco GA 45-90 VSD iPM gives you energy savings of up to 35% for a more sustainable production and significantly lower operational costs.

1 Interior Permanent Magnet (iPM) motor

- Very high efficiency: equals IE4 standards
- Compact, customized design for optimal oil cooling
- IP66, insulation class F, B rise
- No cooling air flow required
- Oil-lubricated motor

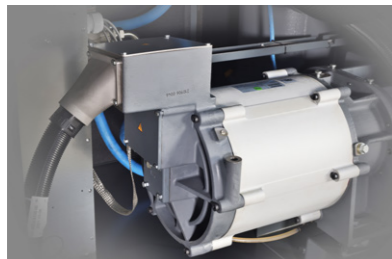

2 Element

- Made by Atlas Copco
- Robust and silent
- High efficiency

3 Premium drive type

- Reliable direct drive for GA 45-75 VSD iPM
- Newly developed gear drive for GA 90 VSD iPM ensures easy maintenance
- Oil-cooled, pressure-tight



4 Classic cooling system

- Separate oil/air cooler
- W-fin cooler is dependable in harsh conditions
- Axial fan enhances cooler performance
- Lower temperature ensures efficient operation

5 Robust oil filter/separator

- Integrated bypass valve with the oil filter
- Optimized spin-on design
- Easy access and maintenance

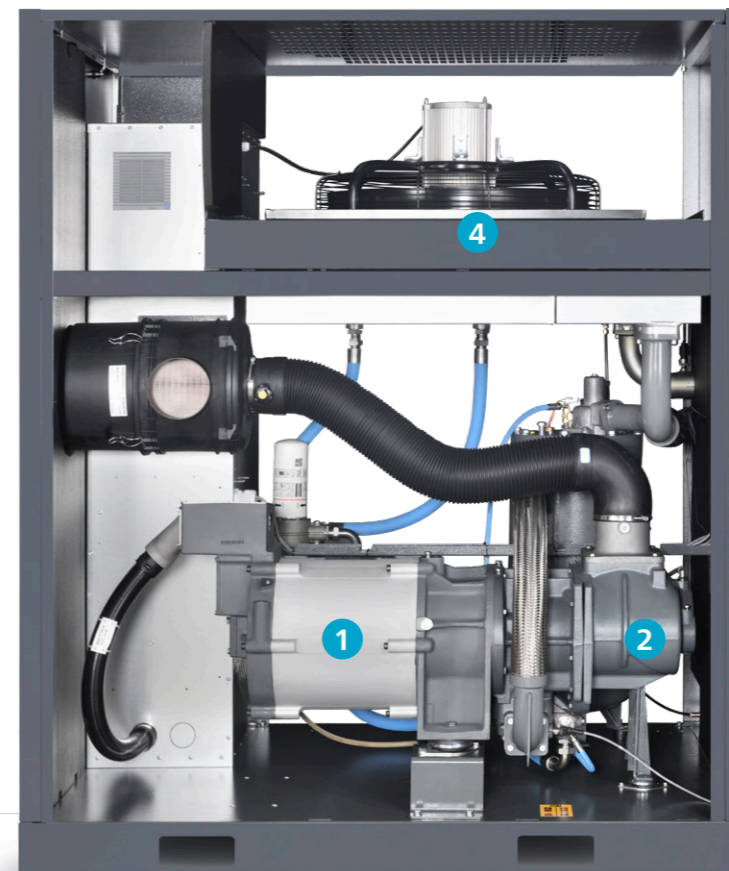

6 Elektronikon® Touch controller

- High-tech controller with warning indications, compressor shutdown and maintenance scheduling
- Standard SMARTLINK remote monitoring to maximize air system performance and energy savings
- Optional multiple compressor control (2, 4 or 6 compressors)



7 Innovative Neos Inverter

- Atlas Copco's in-house designed inverter, now also controls iPM motors
- IP5x protection
- Robust aluminum enclosure for trouble-free operation in the harshest conditions
- Fewer components: compact, simple and user-friendly

VSD iPM: up to 35% energy savings

Atlas Copco's GA Variable Speed Drive iPM technology closely matches the air demand by automatically adjusting the motor speed. This results in energy savings of up to 35%.

Why choose Atlas Copco Variable Speed Drive iPM technology?

- Up to 35% energy savings with an extensive flow range
- Integrated Elektronikon® controller controls the motor speed
- Unique Neos inverter
- Oil-cooled iPM motor means compressor can start/stop under full system pressure without the need to unload
- Eliminates peak current penalty during start-up

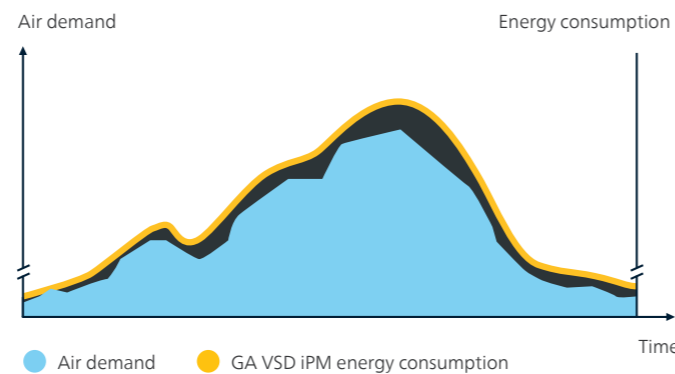
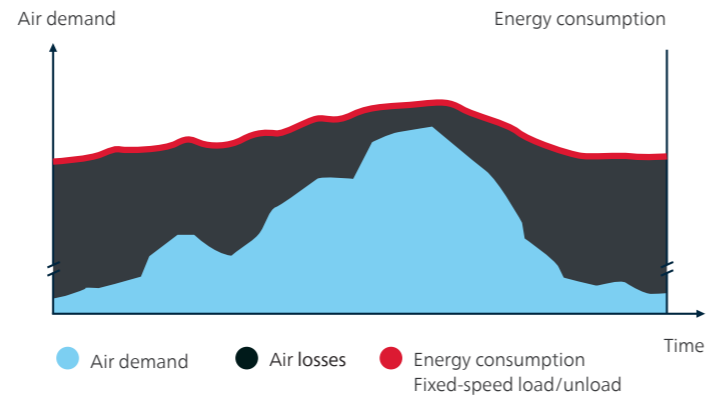

In almost every production environment, air demand fluctuates depending on different factors such as the time of the day, week or even month. Extensive measurements and studies of compressed air demand profiles show that many compressors have substantial variations in air demand.

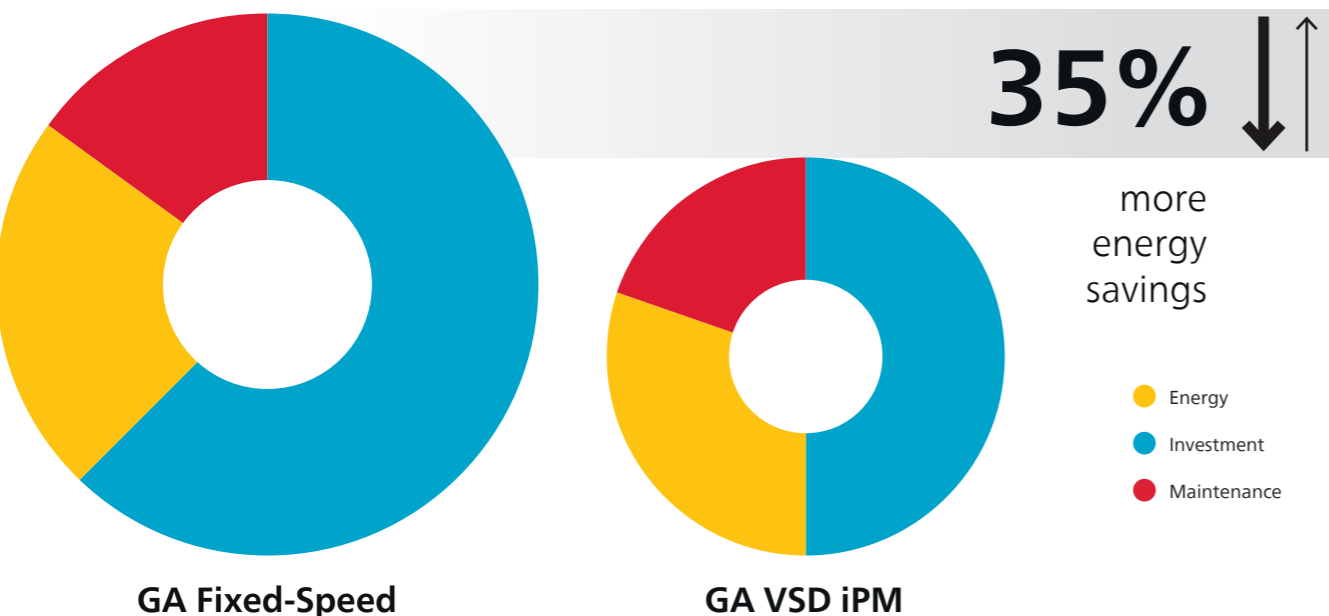

A step ahead in monitoring and controls

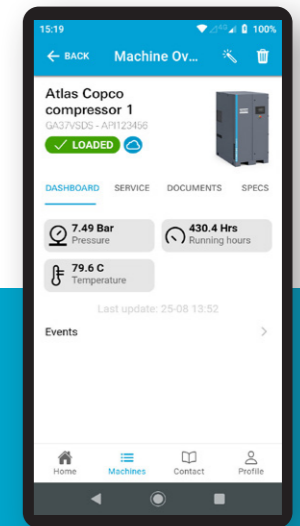

Elektronikon® Touch

- Ease of use: 4.3-inch high-definition color display with clear pictograms and service indicator.
- Reliable: user-friendly, multilingual user interface and durable keyboard.
- Flexible: four different week schedules for 10 consecutive weeks.
- Internet-based compressor visualization with a simple Ethernet connection.
- Remote control and connectivity functions.

SMARTLINK

- SMARTLINK brings real-time monitoring of your compressor's operational parameters to your computer or mobile device:
- Performance data and insights identify opportunities for optimization.
 - Service timeline.
 - Maintenance and service alerts.
 - Online resource center with manuals, documentation and technical information.

Optional multiple compressor controller

The optional multiple compressor controller gives you easy, centralized control to reduce system pressure and energy consumption. Only one license is required for installations of up to 4 (EQ4i) or 6 (EQ6i) compressors.



Technical specifications GA 7-90 VSD iPM

Compressor type	Working pressure		Capacity FAD* (min-max)			Installed motor power		Noise level**	Weight
	bar(e)	psig	l/s	m³/h	cfm	kW	hp		
50/60 Hz version									
GA 7 VSD iPM	4	58	7.3-20.4	26.3-73.4	15.5-43.2	7.5	10	67	175
	7	102	7.1-20.2	25.6-72.7	15.0-42.8	7.5	10	67	175
	10	146	7.0-17.1	25.2-61.6	14.8-36.2	7.5	10	67	175
	12.5	181	8.1-13.2	29.2-47.5	17.2-28.0	7.5	10	67	175
GA 11 VSD iPM	4	58	7.3-30.2	26.3-108.7	15.5-64.0	11	15	67	175
	7	102	7.1-30.0	25.6-180.0	15.0-63.6	11	15	67	175
	10	146	7.0-25.2	25.2-90.7	14.8-53.4	11	15	67	175
	12.5	181	8.1-21.9	29.2-78.8	17.2-46.4	11	15	67	175
GA 15 VSD iPM	4	58	7.3-37.5	26.3-135.0	15.5-79.4	15	20	67	175
	7	102	7.1-37.0	25.6-133.2	15.0-78.4	15	20	67	175
	10	146	7.0-30.3	25.2-109.1	14.8-64.2	15	20	67	175
	12.5	181	8.1-24.7	29.2-88.9	17.2-52.3	15	20	67	175
GA 18 VSD iPM	4	58	11.9-58.6	42.8-211.0	25.2-124.2	18.5	25	70	276
	7	102	11.8-58.3	42.5-209.9	25.0-123.5	18.5	25	70	276
	10	146	10.4-48.7	37.5-175.2	22.1-103.1	18.5	25	70	276
	12.5	181	12.4-42.6	44.6-153.4	26.3-90.3	18.5	25	70	276
GA 22 VSD iPM	4	58	11.9-66.7	42.8-240.0	25.2-141.3	22	30	70	296
	7	102	11.8-66.5	42.5-239.4	25.0-140.9	22	30	70	296
	10	146	10.4-56.5	37.5-203.3	22.1-119.6	22	30	70	296
	12.5	181	12.4-50.0	44.6-180.1	26.3-106.0	22	30	70	296
GA 30 VSD iPM	4	58	15.5-94.1	55.8-338.8	32.8-199.3	30	40	69	522
	7	102	14.6-92.5	52.6-333.0	31.0-196.0	30	40	69	522
	10	146	13.7-82.2	49.3-295.9	29.0-174.0	30	40	69	522
	12.5	181	15.1-69.8	54.4-251.3	31.9-147.9	30	40	69	522
GA 37 VSD iPM	4	58	22.6-115.5	81.4-415.8	47.7-244.6	37	50	69	550
	7	102	22.1-114.5	79.6-412.2	46.8-242.5	37	50	69	550
	10	146	21.0-100.1	75.6-360.4	44.5-212.0	37	50	69	550
	12.5	181	23.2-84.0	83.5-302.4	49.1-177.9	37	50	69	550
GA 45 VSD iPM	4	58	37.8-145.9	136.1-525.2	80.1-309.2	45	60	70	980
	7	102	36.9-145.3	132.8-523.0	78.2-308.0	45	60	70	980
	10	146	35.1-126.4	126.4-455.0	74.4-267.8	45	60	70	980
	12.5	181	39.0-104.5	140.4-376.2	82.6-221.4	45	60	70	980
GA 55 VSD iPM	4	58	40.4-183.7	145.4-661.3	85.6-389.3	55	75	70	985
	7	102	39.5-183.0	142.2-658.8	83.7-387.8	55	75	70	985
	10	146	38.1-162.8	137.2-586.1	80.7-345.0	55	75	70	985
	12.5	181	42.8-137.7	154.1-495.7	90.7-291.8	55	75	70	985
GA 75 VSD iPM	4	58	43.1-226.0	155.2-813.6	91.3-479.1	75	100	73	990
	7	102	42.1-225.0	151.6-810.0	89.2-476.8	75	100	73	990
	10	146	40.9-205.4	147.2-739.4	86.7-435.2	75	100	73	990
	12.5	181	45.7-174.3	164.5-627.5	96.8-369.3	75	100	73	990
GA 90 VSD iPM	4	58	59.7-301.0	214.9-1083.6	126.5-637.8	90	120	73	1170
	7	102	56.9-300.0	204.8-1080.0	120.6-635.7	90	120	73	1170
	10	146	54.6-256.3	196.6-922.7	115.7-543.1	90	120	73	1170
	12.5	181	66.1-223.8	238.0-805.7	140.1-474.2	90	120	73	1170

* Unit performance measured according to ISO 1217 ed. 4 2009, annex E, latest edition.
 ** Mean noise level measured at a distance of 1 m according to ISO 2151: 2004 using ISO 9614/2 (sound intensity method); tolerance 3 dB(A).

Reference conditions:
 - Absolute inlet pressure 1 bar/14.5 psi.
 - Intake air temperature 20°C/68°F.

FAD is measured at the following effective working pressures:

- 4 bar(e)
- 7 bar(e)
- 10 bar(e)
- 12.5 bar(e)

Maximum working pressure: 13 bar(e)/188 psig

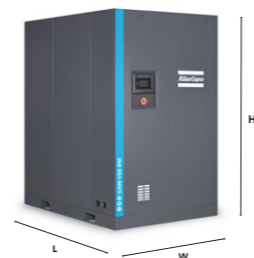

Dimensions

	Standard					
	L (mm)	W (mm)	H (mm)	L (in)	W (in)	H (in)
GA 7-15 VSD iPM	767	623	972	30.20	24.53	38.27
GA 18-22 VSD iPM	978	695	1473	38.50	27.35	58.00
GA 30-37 VSD iPM	1150	820	1620	45.28	32.28	63.78
GA 45-90 VSD iPM	1680	1221	1980	66.14	48.07	77.95

Options

	GA 7-15 VSD iPM	GA 18-22 VSD iPM	GA 30-37 VSD iPM	GA 45-90 VSD iPM
Tropical thermostat	—	✓	✓	✓
Wooden package	✓	✓	✓	✓
RXD oil	✓	✓	✓	✓
Food grade ultra oil	✓	✓	✓	✓
Test report	✓	✓	✓	✓
Witness certificate	✓	✓	✓	✓
Water separator and drain	✓	✓	✓	✓
EMC filter (for China)	✓	—	✓	—

Flow chart GA 7-37 VSD iPM

- Wet compressed air
 - Dry compressed air
 - Intake air
 - Air/oil mixture
 - Oil
- 1 Inlet filter
 - 2 Spring inlet valve
 - 3 Screw element
 - 4 Air/oil vessel separator
 - 5 Oil separator
 - 6 Minimum pressure valve
 - 7 Thermostatic bypass valve
 - 8 Oil filter
 - 9 Motor
 - 10 Oil cooler
 - 11 After cooler
 - 12 Fan
 - 13 Solenoid valve

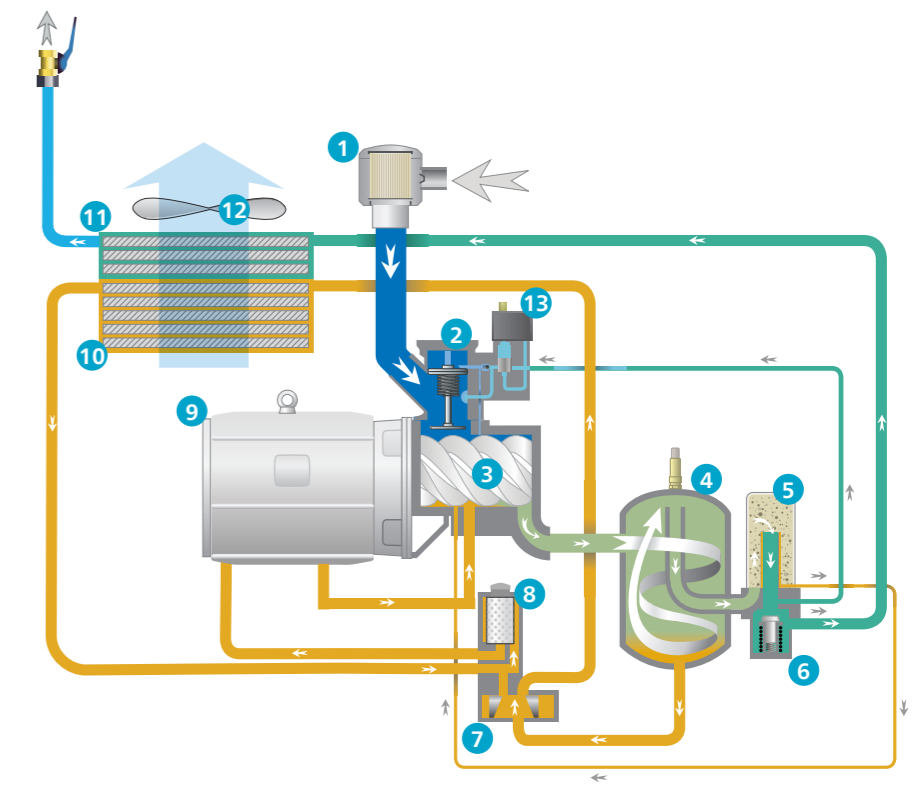

Flow chart GA 45-90 VSD iPM

- Wet compressed air
 - Dry compressed air
 - Intake air
 - Air/oil mixture
 - Oil
- 1 Inlet filter
 - 2 Oil stop valve
 - 3 Screw element
 - 4 Inlet valve
 - 5 Air/oil vessel separator
 - 6 Thermostatic bypass valve
 - 7 Oil filter
 - 8 Safety valve
 - 9 Minimum pressure valve
 - 10 Solenoid valve
 - 11 After cooler
 - 12 Fan
 - 13 Oil cooler

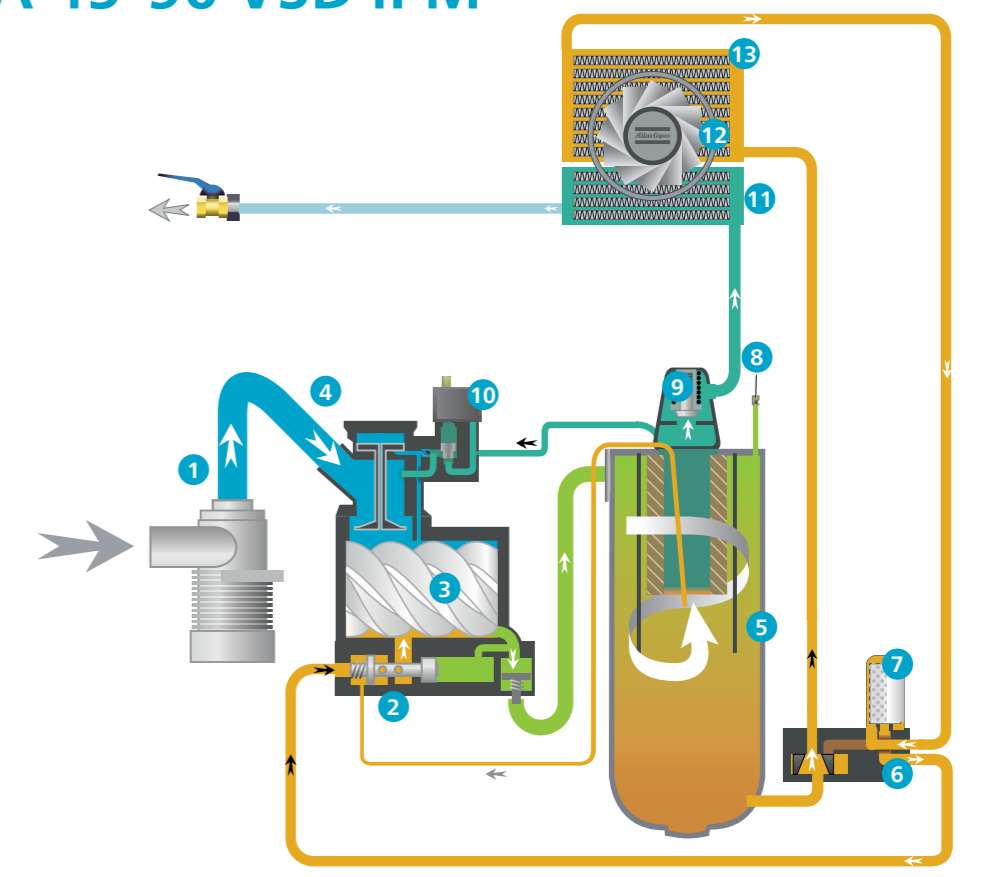



atlascopco.com

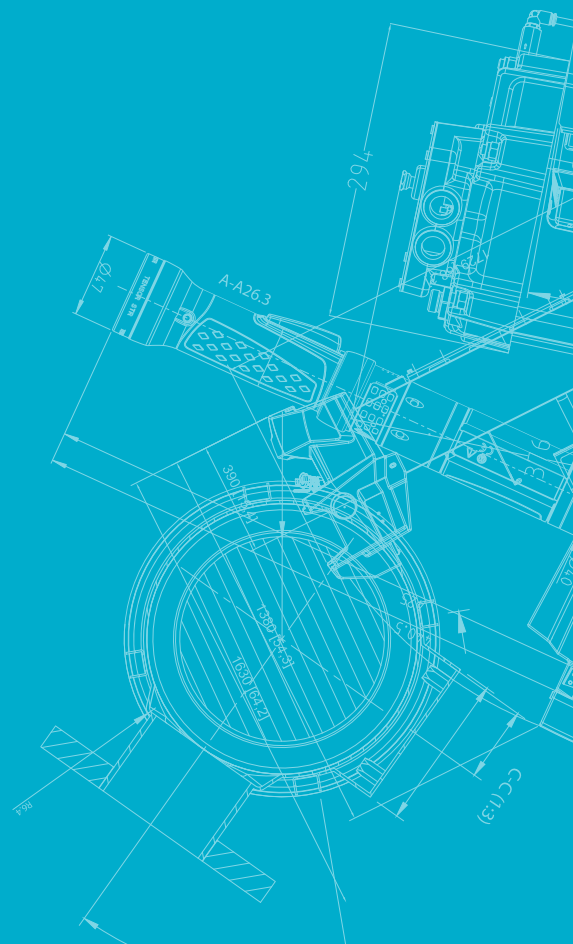

2935 0816 48 ©2022, Atlas Copco. All rights reserved. Designs and specifications are subject to change without notice or obligation. Read all safety instructions in the manual before usage.